

# Lower Thames Crossing

## 2.9 Engineering Drawings and Sections

### Volume H (overhead diversion routes and pylon general arrangement)

APFP Regulation 5(2)(o) and 6(2)

Infrastructure Planning (Applications:  
Prescribed Forms and Procedure)  
Regulations 2009

Volume 2

**DATE: October 2022**

Planning Inspectorate Scheme Ref: TR010032  
Application Document Ref: TR010032/APP/2.9

**VERSION: 1.0**

**(THIS PAGE IS INTENTIONALLY LEFT BLANK)**

# Lower Thames Crossing

## List of contents

	<b>Page number</b>
<b>1 Introduction .....</b>	<b>1</b>
<b>2 Schedule of Plans included in this application document .....</b>	<b>4</b>

# 1 Introduction

- 1.1.1 This document is submitted to the Planning Inspectorate on behalf of the Secretary of State in relation to an application made by National Highways (the Applicant) under section 37 of the Planning Act 2008.
- 1.1.2 The application is for the grant of development consent for the A122 Lower Thames Crossing. Should development consent be granted, the draft A122 (Lower Thames Crossing) Development Consent Order (Application Document 3.1) (the draft Order) will be made by the Secretary of State (subject to any modifications considered appropriate).
- 1.1.3 This document comprises part of the suite of application documentation and is included in the application to comply with Regulations 5(2)(o) and 6(2) of the Infrastructure Planning (Applications: Prescribed Forms and Procedure) Regulations 2009 (the 2009 Regulations), which require:
- a. *5(2)(o) 'any other plans, drawings and sections necessary to describe the proposals for which development consent is sought, showing details of design, external appearance, and the preferred layout of buildings or structures, drainage, surface water management, means of vehicular and pedestrian access, any car parking to be provided, and means of landscaping.*
  - b. *6(2) If the application is for highway related development or for the construction or alteration of a railway, it must be accompanied by section drawings to suitable horizontal and vertical scales, which show, by reference to Ordnance Survey or Chart datum:*
    - i. *ground levels;*
    - ii. *the height of every proposed bridge, viaduct, aqueduct, embankment and elevated guideway;*
    - iii. *the depth of every proposed cutting and tunnel;*
    - iv. *the levels of the bed of any tidal waters or inland waterway in which it is proposed that any works should be situated;*
    - v. *the height of every structure or device (including a cable, but not catenary and related equipment) intended to be erected above, on or below the surface of, or on or beneath the bed of tidal waters or an inland waterway; and*
    - vi. *drainage outfall details for highways;*

- 1.1.4 The purpose of the Engineering Drawings and Sections Plans is to show the key features of the Project for which development consent is sought. The set shows details of the proposed road plan and longitudinal profile including the ground levels, the height of certain structures and embankments, the depth of proposed cuttings and tunnel, and the indicative location and level of drainage outfall features.
- 1.1.6 For each section, the Applicant has provided a key plan of the corresponding geographical area that provides the sheet number and a description of the associated road works to help with its identification within the set. It is important to note that the plans are numbered in each of the aforementioned sections and that the numbering system does not apply to the set as whole.
- 1.1.7 The key plans use a smaller scale than that prescribed in Regulation 5(3) of the 2009 Regulations so that the Project or the section of the Project can be represented in a single sheet plan. The scales in the key plans vary from 1:50000 to 1:5000. The remaining sheets in the set containing the plan and profiles and the cross sections have been prepared at a horizontal scale of 1:2500 and a vertical scale of 1:250.
- 1.1.8 As this document has been informed by and is part of the application documentation it should be read alongside the other application documents. In particular, the plans should be read alongside the Works Plans (Application Document 2.6) and Schedule 1 of the draft Order (Application Document 3.1). Article 6 of the draft Order should also be referred to as it provides the reference points for the application of the upwards and downwards vertical limits of deviation applicable to the elements of the works.
- 1.1.9 Numbered works shown in the Engineering Drawings and Sections Plans are consistent with the information presented in the Works Plans (Application Document 2.6) and Schedule 1 of the draft Order (Application Document 3.1). Further details of the proposed bridges and tunnel structures are provided in the Structures Plans (Application Document 2.13).
- 1.1.10 The information shown on the plans is commensurate with the preliminary design status of the Project. The detailed design will be in accordance with the extent of the defined limits of deviation provided and any approval required under the DCO requirements set out in Schedule 2 of the draft Order (Application Document 3.1).
- 1.1.11 The lateral limits of deviation for the works are shown in the Works Plans (Application Document 2.6) and in the Tunnel Limits of Deviation (Application Document 2.15); article 6 of the draft Order establishes the vertical limits of deviation. Further information about the limits of deviation is provided in the Introduction to the Application (Application Document 1.3).
- 1.1.6 The Engineering Drawings and Sections show the Order Limits. In this plan set, 'the Order Limits' mean the limits of lands to be acquired or used, permanently or temporarily, within which the authorised development may be carried out (see article 2 of the draft Order (Application Document 3.1)).
- 1.1.7 To ensure that the file size of this document does not exceed the 50MB limit prescribed by the Planning Inspectorate, the set has been split into eight volumes:

- a. Volume A contains the A122 Lower Thames Crossing Plan and Profiles;
- b. Volume B contains the A122 Lower Thames Crossing Cross Sections;
- c. Volume C contains the A2/M2 Plan and Profiles and A2 Mainline Plan and Profiles;
- d. Volume D contains the A122 Lower Thames Crossing/A2 Junction Plan and Profiles;
- e. Volume E contains the South Portal Plan and Profiles and Tilbury Plan and Profiles;
- f. Volume F contains the A13 Junction Plan and Profile;
- g. Volume G contains the A122 Lower Thames Crossing/M25 Junction Plan; and
- h. Volume H contains the Overhead Diversion Route and Pylon general arrangements.

## 2 Schedule of Plans included in this application document

Document Title	Document Number	Revision
A122 LTC PLAN AND PROFILES REGULATION 5(2)(o) AND 6(2) KEY PLAN	TR010032/APP/2.9	P01
A122 LTC PLAN AND PROFILES REGULATION 5(2)(o) AND 6(2) SHEET 1	TR010032/APP/2.9	P01
A122 LTC PLAN AND PROFILES REGULATION 5(2)(o) AND 6(2) SHEET 2	TR010032/APP/2.9	P01
A122 LTC PLAN AND PROFILES REGULATION 5(2)(o) AND 6(2) SHEET 3	TR010032/APP/2.9	P01
A122 LTC PLAN AND PROFILES REGULATION 5(2)(o) AND 6(2) SHEET 4	TR010032/APP/2.9	P01
A122 LTC PLAN AND PROFILES REGULATION 5(2)(o) AND 6(2) SHEET 5	TR010032/APP/2.9	P01
A122 LTC PLAN AND PROFILES REGULATION 5(2)(o) AND 6(2) SHEET 6	TR010032/APP/2.9	P01
A122 LTC PLAN AND PROFILES REGULATION 5(2)(o) AND 6(2) SHEET 7	TR010032/APP/2.9	P01
A122 LTC PLAN AND PROFILES REGULATION 5(2)(o) AND 6(2) SHEET 8	TR010032/APP/2.9	P01
A122 LTC PLAN AND PROFILES REGULATION 5(2)(o) AND 6(2) SHEET 9	TR010032/APP/2.9	P01
A122 LTC PLAN AND PROFILES REGULATION 5(2)(o) AND 6(2) SHEET 10	TR010032/APP/2.9	P01
A122 LTC PLAN AND PROFILES REGULATION 5(2)(o) AND 6(2) SHEET 11	TR010032/APP/2.9	P01
A122 LTC PLAN AND PROFILES REGULATION 5(2)(o) AND 6(2) SHEET 12	TR010032/APP/2.9	P01

<b>Document Title</b>	<b>Document Number</b>	<b>Revision</b>
A122 LTC PLAN AND PROFILES REGULATION 5(2)(o) AND 6(2) SHEET 13	TR010032/APP/2.9	P01
A122 LTC PLAN AND PROFILES REGULATION 5(2)(o) AND 6(2) SHEET 14	TR010032/APP/2.9	P01
CROSS SECTIONS REGULATION 5(2)(o) AND 6(2) KEY PLAN	TR010032/APP/2.9	P01
CROSS SECTIONS REGULATION 5(2)(o) AND 6(2) SHEET 1	TR010032/APP/2.9	P01
CROSS SECTIONS REGULATION 5(2)(o) AND 6(2) SHEET 2	TR010032/APP/2.9	P01
CROSS SECTIONS REGULATION 5(2)(o) AND 6(2) SHEET 3	TR010032/APP/2.9	P01
CROSS SECTIONS REGULATION 5(2)(o) AND 6(2) SHEET 4	TR010032/APP/2.9	P01
CROSS SECTIONS REGULATION 5(2)(o) AND 6(2) SHEET 5	TR010032/APP/2.9	P01
CROSS SECTIONS REGULATION 5(2)(o) AND 6(2) SHEET 6	TR010032/APP/2.9	P01
CROSS SECTIONS REGULATION 5(2)(o) AND 6(2) SHEET 7	TR010032/APP/2.9	P01
CROSS SECTIONS REGULATION 5(2)(o) AND 6(2) SHEET 8	TR010032/APP/2.9	P01
CROSS SECTIONS REGULATION 5(2)(o) AND 6(2) SHEET 9	TR010032/APP/2.9	P01
CROSS SECTIONS REGULATION 5(2)(o) AND 6(2) SHEET 10	TR010032/APP/2.9	P01
CROSS SECTIONS REGULATION 5(2)(o) AND 6(2) SHEET 11	TR010032/APP/2.9	P01



<b>Document Title</b>	<b>Document Number</b>	<b>Revision</b>
CROSS SECTIONS REGULATION 5(2)(o) AND 6(2) SHEET 12	TR010032/APP/2.9	P01
CROSS SECTIONS REGULATION 5(2)(o) AND 6(2) SHEET 13	TR010032/APP/2.9	P01
CROSS SECTIONS REGULATION 5(2)(o) AND 6(2) SHEET 14	TR010032/APP/2.9	P01
CROSS SECTIONS REGULATION 5(2)(o) AND 6(2) SHEET 15	TR010032/APP/2.9	P01
CROSS SECTIONS REGULATION 5(2)(o) AND 6(2) SHEET 16	TR010032/APP/2.9	P01
CROSS SECTIONS REGULATION 5(2)(o) AND 6(2) SHEET 17	TR010032/APP/2.9	P01
CROSS SECTIONS REGULATION 5(2)(o) AND 6(2) SHEET 18	TR010032/APP/2.9	P01
A2/M2 PLAN AND PROFILES REGULATION 5(2)(o) AND 6(2) KEY PLAN	TR010032/APP/2.9	P01
A2/M2 PLAN AND PROFILES REGULATION 5(2)(o) AND 6(2) SHEET 1	TR010032/APP/2.9	P01
A2/M2 PLAN AND PROFILES REGULATION 5(2)(o) AND 6(2) SHEET 2	TR010032/APP/2.9	P01
A2/M2 PLAN AND PROFILES REGULATION 5(2)(o) AND 6(2) SHEET 3	TR010032/APP/2.9	P01
A2/M2 PLAN AND PROFILES REGULATION 5(2)(o) AND 6(2) SHEET 4	TR010032/APP/2.9	P01
A2/M2 PLAN AND PROFILES REGULATION 5(2)(o) AND 6(2) SHEET 5	TR010032/APP/2.9	P01
A2/M2 PLAN AND PROFILES REGULATION 5(2)(o) AND 6(2) SHEET 6	TR010032/APP/2.9	P01

<b>Document Title</b>	<b>Document Number</b>	<b>Revision</b>
A2 MAINLINE – PLAN AND PROFILES REGULATION 5(2)(o) AND 6(2) KEY PLAN	TR010032/APP/2.9	P01
A2 MAINLINE – PLAN AND PROFILES REGULATION 5(2)(o) AND 6(2) SHEET 1	TR010032/APP/2.9	P01
A2 MAINLINE – PLAN AND PROFILES REGULATION 5(2)(o) AND 6(2) SHEET 2	TR010032/APP/2.9	P01
A2 MAINLINE – PLAN AND PROFILES REGULATION 5(2)(o) AND 6(2) SHEET 3	TR010032/APP/2.9	P01
A2 MAINLINE – PLAN AND PROFILES REGULATION 5(2)(o) AND 6(2) SHEET 4	TR010032/APP/2.9	P01
A122 LTC/A2 JCT – PLAN AND PROFILES REGULATION 5(2)(o) AND 6(2) KEY PLAN	TR010032/APP/2.9	P01
A122 LTC/A2 JCT – PLAN AND PROFILES REGULATION 5(2)(o) AND 6(2) SHEET 1	TR010032/APP/2.9	P01
A122 LTC/A2 JCT – PLAN AND PROFILES REGULATION 5(2)(o) AND 6(2) SHEET 2	TR010032/APP/2.9	P01
A122 LTC/A2 JCT – PLAN AND PROFILES REGULATION 5(2)(o) AND 6(2) SHEET 3	TR010032/APP/2.9	P01
A122 LTC/A2 JCT – PLAN AND PROFILES REGULATION 5(2)(o) AND 6(2) SHEET 4	TR010032/APP/2.9	P01
A122 LTC/A2 JCT – PLAN AND PROFILES REGULATION 5(2)(o) AND 6(2) SHEET 5	TR010032/APP/2.9	P01
A122 LTC/A2 JCT – PLAN AND PROFILES REGULATION 5(2)(o) AND 6(2) SHEET 6	TR010032/APP/2.9	P01
A122 LTC/A2 JCT – PLAN AND PROFILES REGULATION 5(2)(o) AND 6(2) SHEET 7	TR010032/APP/2.9	P01
A122 LTC/A2 JCT – PLAN AND PROFILES REGULATION 5(2)(o) AND 6(2) SHEET 8	TR010032/APP/2.9	P01

<b>Document Title</b>	<b>Document Number</b>	<b>Revision</b>
A122 LTC/A2 JCT – PLAN AND PROFILES REGULATION 5(2)(o) AND 6(2) SHEET 9	TR010032/APP/2.9	P01
A122 LTC/A2 JCT – PLAN AND PROFILES REGULATION 5(2)(o) AND 6(2) SHEET 10	TR010032/APP/2.9	P01
A122 LTC/A2 JCT – PLAN AND PROFILES REGULATION 5(2)(o) AND 6(2) SHEET 11	TR010032/APP/2.9	P01
A122 LTC/A2 JCT – PLAN AND PROFILES REGULATION 5(2)(o) AND 6(2) SHEET 12	TR010032/APP/2.9	P01
A122 LTC/A2 JCT – PLAN AND PROFILES REGULATION 5(2)(o) AND 6(2) SHEET 13	TR010032/APP/2.9	P01
A122 LTC/A2 JCT – PLAN AND PROFILES REGULATION 5(2)(o) AND 6(2) SHEET 14	TR010032/APP/2.9	P01
A122 LTC/A2 JCT – PLAN AND PROFILES REGULATION 5(2)(o) AND 6(2) SHEET 15	TR010032/APP/2.9	P01
A122 LTC/A2 JCT – PLAN AND PROFILES REGULATION 5(2)(o) AND 6(2) SHEET 16	TR010032/APP/2.9	P01
SOUTH PORTAL – PLAN AND PROFILES REGULATION 5(2)(o) AND 6(2) KEY PLAN	TR010032/APP/2.9	P01
SOUTH PORTAL – PLAN AND PROFILES REGULATION 5(2)(o) AND 6(2) SHEET 1	TR010032/APP/2.9	P01
SOUTH PORTAL – PLAN AND PROFILES REGULATION 5(2)(o) AND 6(2) SHEET 2	TR010032/APP/2.9	P01
TILBURY – PLAN AND PROFILES REGULATION 5(2)(o) AND 6(2) KEY PLAN	TR010032/APP/2.9	P01
TILBURY – PLAN AND PROFILES REGULATION 5(2)(o) AND 6(2) SHEET 1	TR010032/APP/2.9	P01
TILBURY – PLAN AND PROFILES REGULATION 5(2)(o) AND 6(2) SHEET 2	TR010032/APP/2.9	P01

<b>Document Title</b>	<b>Document Number</b>	<b>Revision</b>
TILBURY – PLAN AND PROFILES REGULATION 5(2)(o) AND 6(2) SHEET 3	TR010032/APP/2.9	P01
TILBURY – PLAN AND PROFILES REGULATION 5(2)(o) AND 6(2) SHEET 4	TR010032/APP/2.9	P01
TILBURY – PLAN AND PROFILES REGULATION 5(2)(o) AND 6(2) SHEET 5	TR010032/APP/2.9	P01
TILBURY – PLAN AND PROFILES REGULATION 5(2)(o) AND 6(2) SHEET 6	TR010032/APP/2.9	P01
TILBURY – PLAN AND PROFILES REGULATION 5(2)(o) AND 6(2) SHEET 7	TR010032/APP/2.9	P01
A13 JUNCTION – PLAN AND PROFILES REGULATION 5(2)(o) AND 6(2) KEY PLAN	TR010032/APP/2.9	P01
A13 JUNCTION – PLAN AND PROFILES REGULATION 5(2)(o) AND 6(2) SHEET 1	TR010032/APP/2.9	P01
A13 JUNCTION – PLAN AND PROFILES REGULATION 5(2)(o) AND 6(2) SHEET 2	TR010032/APP/2.9	P01
A13 JUNCTION – PLAN AND PROFILES REGULATION 5(2)(o) AND 6(2) SHEET 3	TR010032/APP/2.9	P01
A13 JUNCTION – PLAN AND PROFILES REGULATION 5(2)(o) AND 6(2) SHEET 4	TR010032/APP/2.9	P01
A13 JUNCTION – PLAN AND PROFILES REGULATION 5(2)(o) AND 6(2) SHEET 5	TR010032/APP/2.9	P01
A13 JUNCTION – PLAN AND PROFILES REGULATION 5(2)(o) AND 6(2) SHEET 6	TR010032/APP/2.9	P01
A13 JUNCTION – PLAN AND PROFILES REGULATION 5(2)(o) AND 6(2) SHEET 7	TR010032/APP/2.9	P01
A13 JUNCTION – PLAN AND PROFILES REGULATION 5(2)(o) AND 6(2) SHEET 8	TR010032/APP/2.9	P01

<b>Document Title</b>	<b>Document Number</b>	<b>Revision</b>
A13 JUNCTION – PLAN AND PROFILES REGULATION 5(2)(o) AND 6(2) SHEET 9	TR010032/APP/2.9	P01
A13 JUNCTION – PLAN AND PROFILES REGULATION 5(2)(o) AND 6(2) SHEET 10	TR010032/APP/2.9	P01
A13 JUNCTION – PLAN AND PROFILES REGULATION 5(2)(o) AND 6(2) SHEET 11	TR010032/APP/2.9	P01
A13 JUNCTION – PLAN AND PROFILES REGULATION 5(2)(o) AND 6(2) SHEET 12	TR010032/APP/2.9	P01
A13 JUNCTION – PLAN AND PROFILES REGULATION 5(2)(o) AND 6(2) SHEET 13	TR010032/APP/2.9	P01
A13 JUNCTION – PLAN AND PROFILES REGULATION 5(2)(o) AND 6(2) SHEET 14	TR010032/APP/2.9	P01
A13 JUNCTION – PLAN AND PROFILES REGULATION 5(2)(o) AND 6(2) SHEET 15	TR010032/APP/2.9	P01
A13 JUNCTION – PLAN AND PROFILES REGULATION 5(2)(o) AND 6(2) SHEET 16	TR010032/APP/2.9	P01
A13 JUNCTION – PLAN AND PROFILES REGULATION 5(2)(o) AND 6(2) SHEET 17	TR010032/APP/2.9	P01
A13 JUNCTION – PLAN AND PROFILES REGULATION 5(2)(o) AND 6(2) SHEET 18	TR010032/APP/2.9	P01
A13 JUNCTION – PLAN AND PROFILES REGULATION 5(2)(o) AND 6(2) SHEET 19	TR010032/APP/2.9	P01
A13 JUNCTION – PLAN AND PROFILES REGULATION 5(2)(o) AND 6(2) SHEET 20	TR010032/APP/2.9	P01
A13 JUNCTION – PLAN AND PROFILES REGULATION 5(2)(o) AND 6(2) SHEET 21	TR010032/APP/2.9	P01
A13 JUNCTION – PLAN AND PROFILES REGULATION 5(2)(o) AND 6(2) SHEET 22	TR010032/APP/2.9	P01

<b>Document Title</b>	<b>Document Number</b>	<b>Revision</b>
A13 JUNCTION – PLAN AND PROFILES REGULATION 5(2)(o) AND 6(2) SHEET 23	TR010032/APP/2.9	P01
A122 LTC/M25 JUNCTION REGULATION 5(2)(o) AND 6(2) KEY PLAN	TR010032/APP/2.9	P01
A122 LTC/M25 JUNCTION REGULATION 5(2)(o) AND 6(2) SHEET 1	TR010032/APP/2.9	P01
A122 LTC/M25 JUNCTION REGULATION 5(2)(o) AND 6(2) SHEET 2	TR010032/APP/2.9	P01
A122 LTC/M25 JUNCTION REGULATION 5(2)(o) AND 6(2) SHEET 3	TR010032/APP/2.9	P01
A122 LTC/M25 JUNCTION REGULATION 5(2)(o) AND 6(2) SHEET 4	TR010032/APP/2.9	P01
A122 LTC/M25 JUNCTION REGULATION 5(2)(o) AND 6(2) SHEET 5	TR010032/APP/2.9	P01
A122 LTC/M25 JUNCTION REGULATION 5(2)(o) AND 6(2) SHEET 6	TR010032/APP/2.9	P01
A122 LTC/M25 JUNCTION REGULATION 5(2)(o) AND 6(2) SHEET 7	TR010032/APP/2.9	P01
A122 LTC/M25 JUNCTION REGULATION 5(2)(o) AND 6(2) SHEET 8	TR010032/APP/2.9	P01
A122 LTC/M25 JUNCTION REGULATION 5(2)(o) AND 6(2) SHEET 9	TR010032/APP/2.9	P01
A122 LTC/M25 JUNCTION REGULATION 5(2)(o) AND 6(2) SHEET 10	TR010032/APP/2.9	P01
A122 LTC/M25 JUNCTION REGULATION 5(2)(o) AND 6(2) SHEET 11	TR010032/APP/2.9	P01
A122 LTC/M25 JUNCTION REGULATION 5(2)(o) AND 6(2) SHEET 12	TR010032/APP/2.9	P01

<b>Document Title</b>	<b>Document Number</b>	<b>Revision</b>
A122 LTC/M25 JUNCTION REGULATION 5(2)(o) AND 6(2) SHEET 13	TR010032/APP/2.9	P01
A122 LTC/M25 JUNCTION REGULATION 5(2)(o) AND 6(2) SHEET 14	TR010032/APP/2.9	P01
A122 LTC/M25 JUNCTION REGULATION 5(2)(o) AND 6(2) SHEET 15	TR010032/APP/2.9	P01
A122 LTC/M25 JUNCTION REGULATION 5(2)(o) AND 6(2) SHEET 16	TR010032/APP/2.9	P01
OVERHEAD DIVERSION ROUTE REGULATION 5(2)(o) AND 6(2) PYLON LAYOUT	TR010032/APP/2.9	P01
OVERHEAD DIVERSION ROUTE REGULATION 5(2)(o) AND 6(2) SHEET 1	TR010032/APP/2.9	P01
OVERHEAD DIVERSION ROUTE REGULATION 5(2)(o) AND 6(2) SHEET 2	TR010032/APP/2.9	P01
OVERHEAD DIVERSION ROUTE REGULATION 5(2)(o) AND 6(2) SHEET 3	TR010032/APP/2.9	P01
OVERHEAD DIVERSION ROUTE REGULATION 5(2)(o) AND 6(2) SHEET 4	TR010032/APP/2.9	P01
OVERHEAD DIVERSION ROUTE REGULATION 5(2)(o) AND 6(2) SHEET 5	TR010032/APP/2.9	P01
OVERHEAD DIVERSION ROUTE REGULATION 5(2)(o) AND 6(2) SHEET 6	TR010032/APP/2.9	P01
PYLON GENERAL ARRANGEMENT REGULATION 5(2)(o) AND 6(2) SHEET 1	TR010032/APP/2.9	P01
PYLON GENERAL ARRANGEMENT REGULATION 5(2)(o) AND 6(2) SHEET 2	TR010032/APP/2.9	P01
PYLON GENERAL ARRANGEMENT REGULATION 5(2)(o) AND 6(2) SHEET 3 - L7c D E12	TR010032/APP/2.9	P01
PYLON GENERAL ARRANGEMENT REGULATION 5(2)(o) AND 6(2) SHEET 4 - L7c D30 E12	TR010032/APP/2.9	P01

<b>Document Title</b>	<b>Document Number</b>	<b>Revision</b>
PYLON GENERAL ARRANGEMENT REGULATION 5(2)(o) AND 6(2) SHEET 5 - L7c D E3	TR010032/APP/2.9	P01
PYLON GENERAL ARRANGEMENT REGULATION 5(2)(o) AND 6(2) SHEET 6 - L7c D30 E9	TR010032/APP/2.9	P01
PYLON GENERAL ARRANGEMENT REGULATION 5(2)(o) AND 6(2) SHEET 7 - L7c DT E9	TR010032/APP/2.9	P01



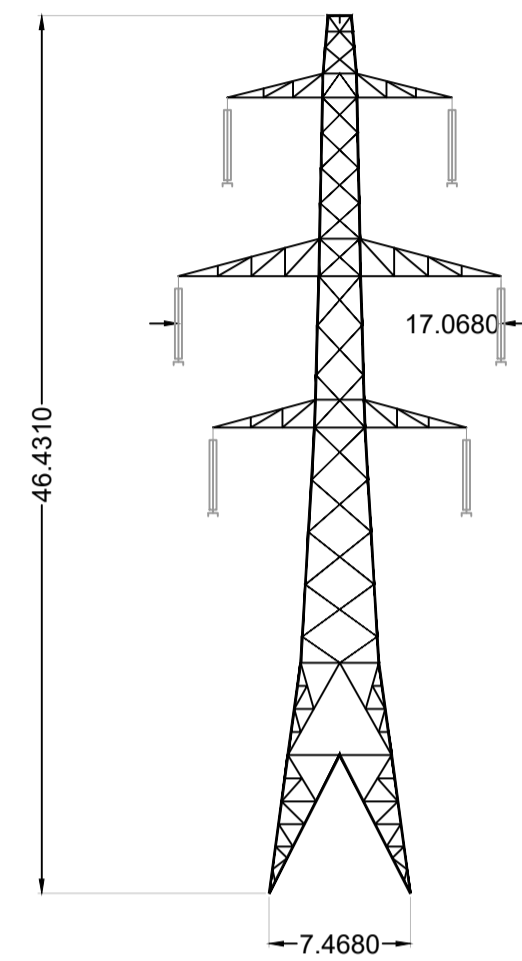

L8c D STD 275/400kV  
LATTICE PYLON  
SUSPENSION

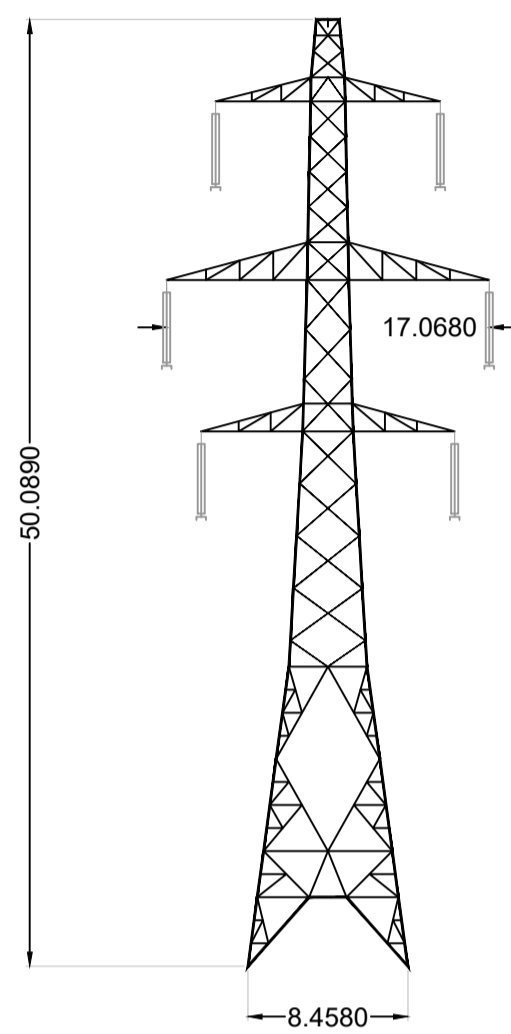

L8c D E3.7 275/400kV  
LATTICE PYLON  
SUSPENSION

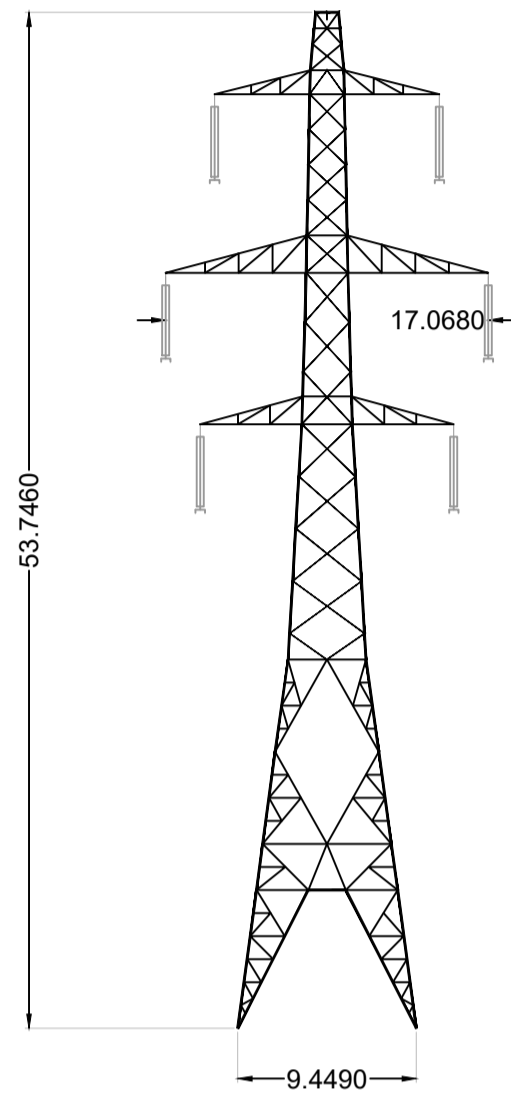

L8c D E7.3 275/400kV  
LATTICE PYLON  
SUSPENSION

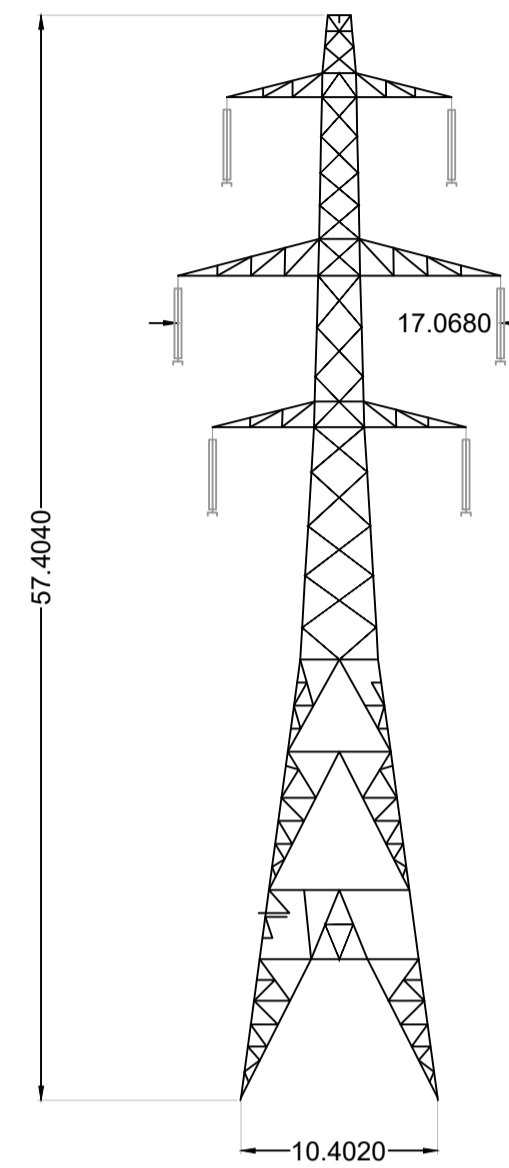

L8c D E11 (BK) 275/400kV  
LATTICE PYLON  
SUSPENSION

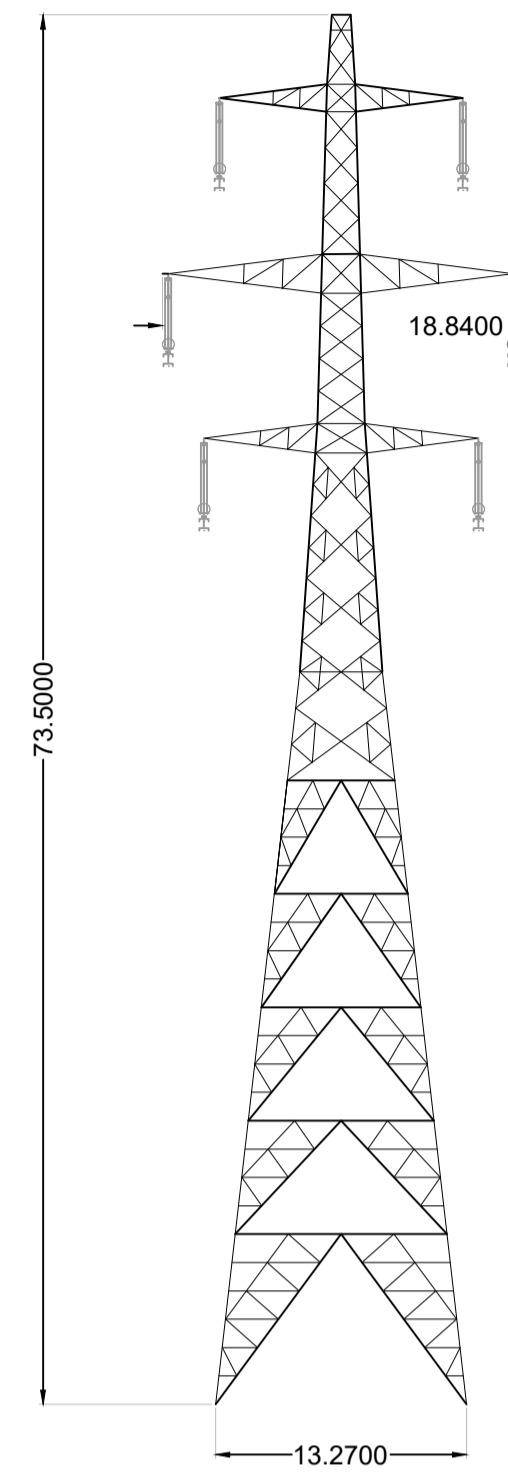

L12 D E27 400kV  
LATTICE PYLON  
SUSPENSION

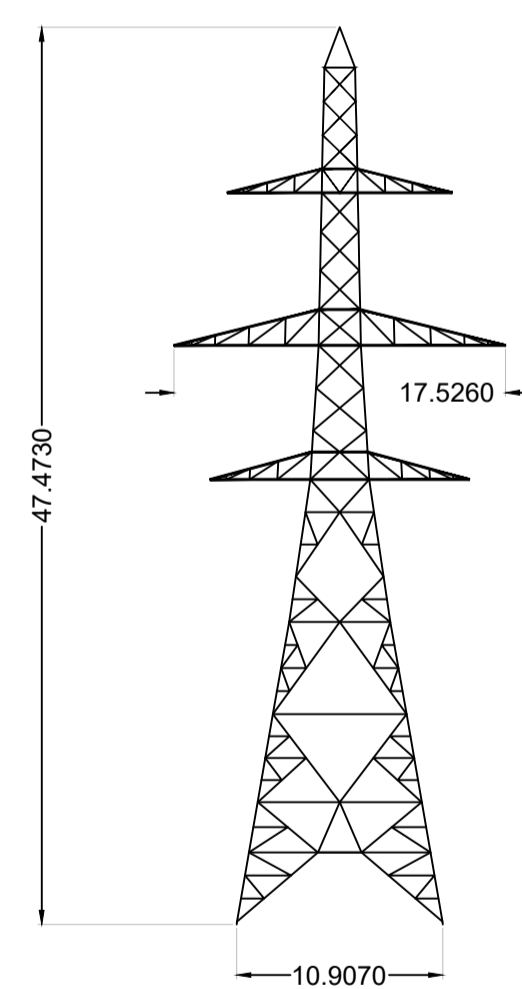

L8c D10 E3.7 275/400kV  
LATTICE PYLON  
TENSION

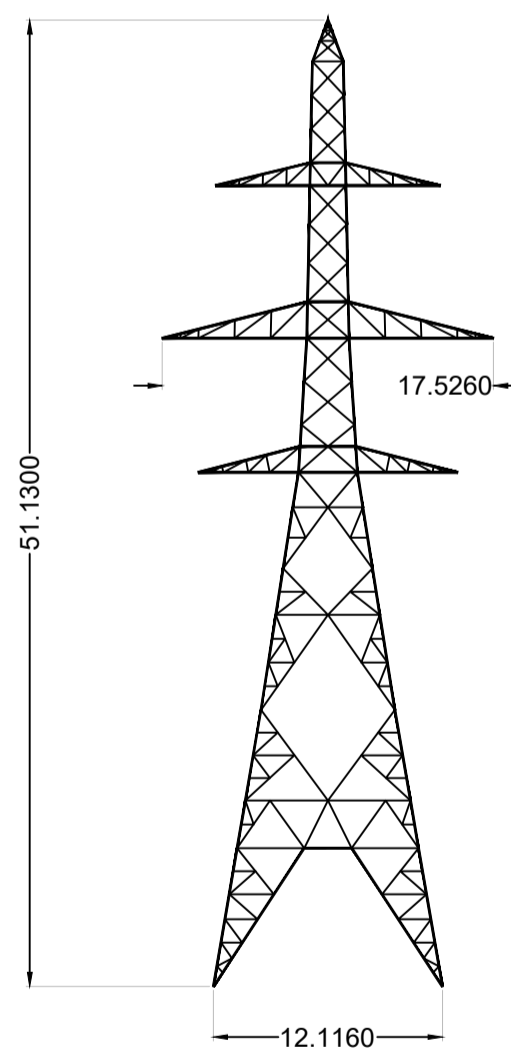

L8c D30 E7.3 275/400kV  
LATTICE PYLON  
TENSION

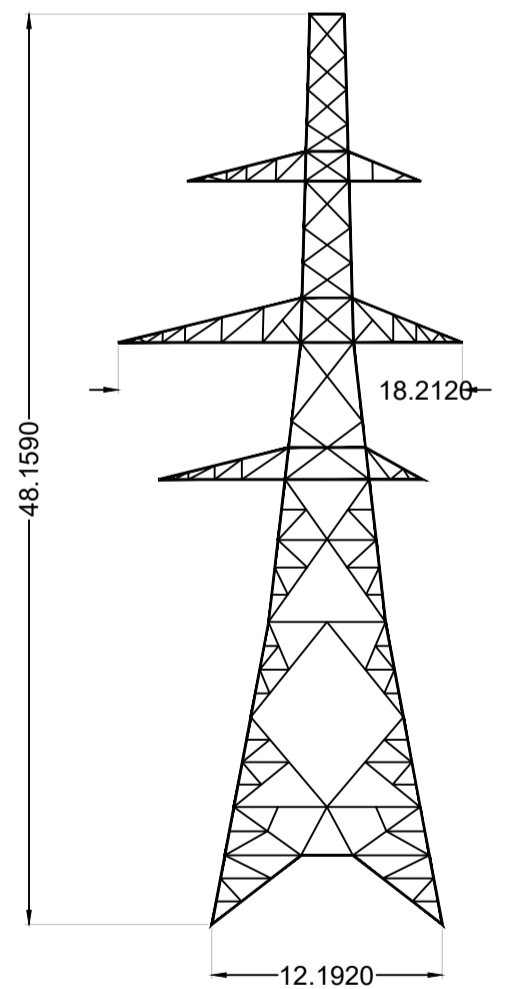

L8c D60 E3.7 275/400kV  
LATTICE PYLON  
TENSION

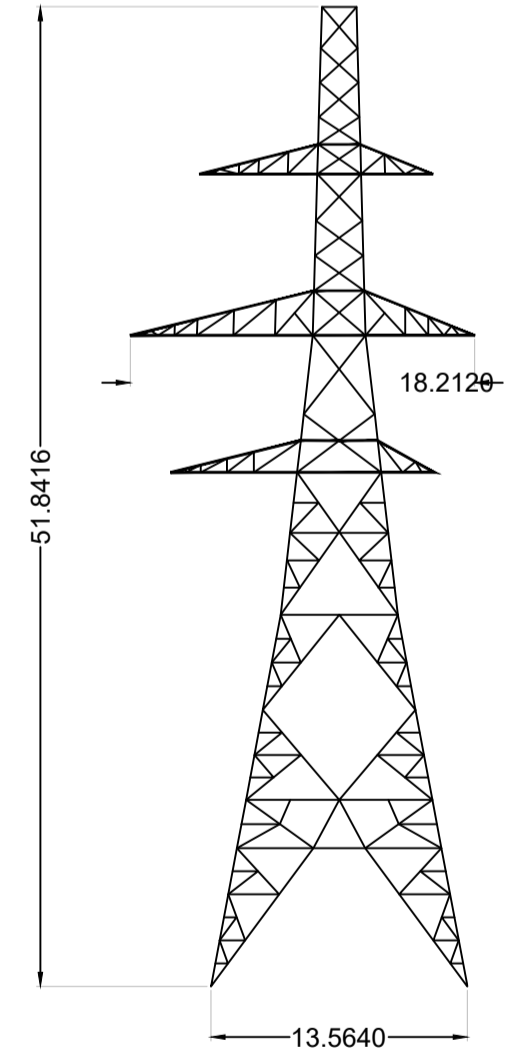

L8c D60 E7.3 275/400kV  
LATTICE PYLON  
TENSION

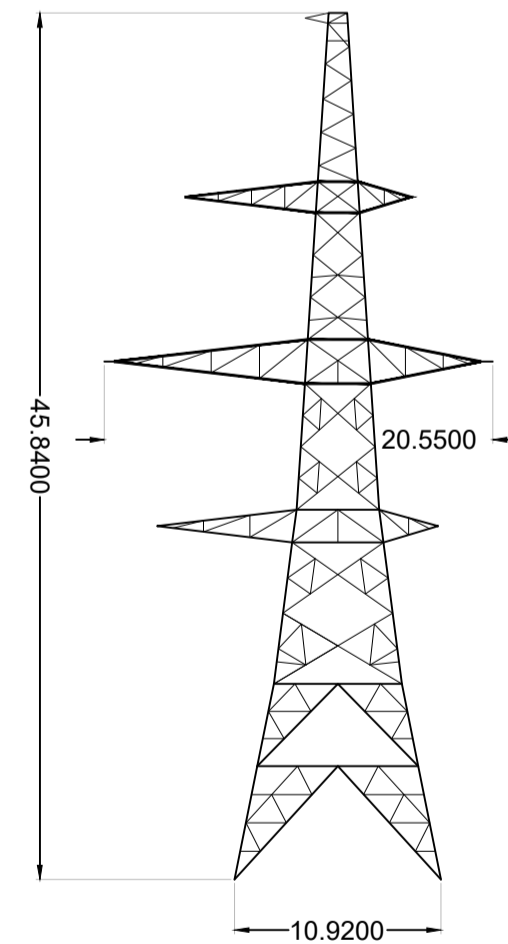

L12 D55 STD 400kV  
LATTICE PYLON  
TENSION

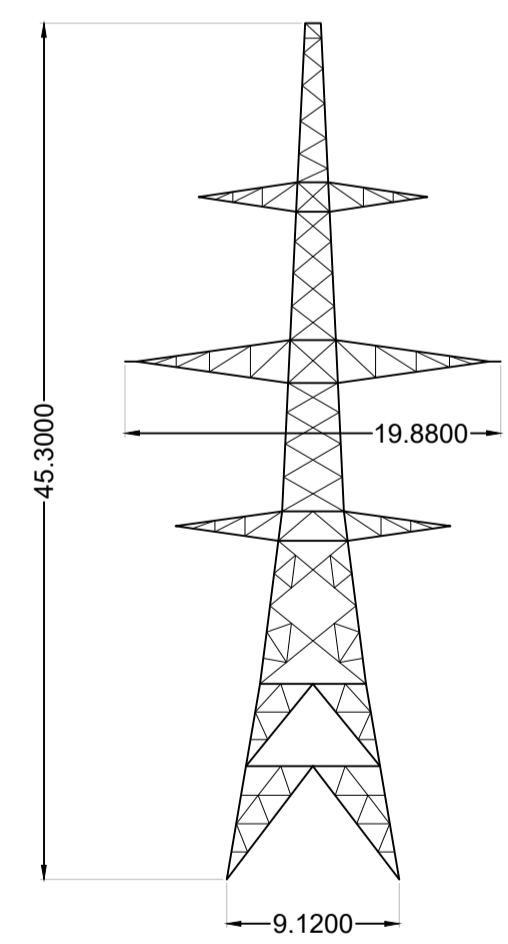

L12 D25 STD  
LATTICE PYLON  
TENSION

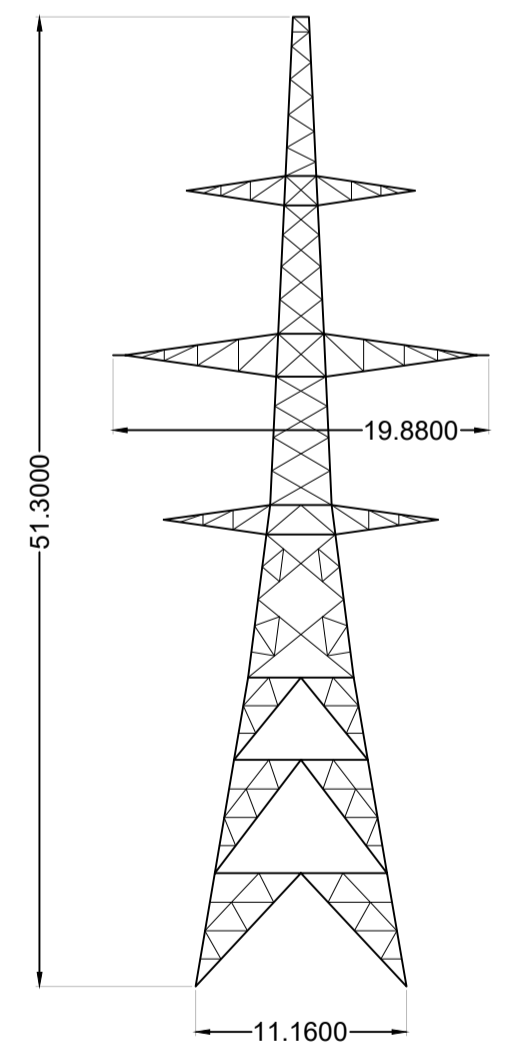

L12 D25 E6  
LATTICE PYLON  
TENSION

**NOTES:**  
1. The proposed design of the structure shown is illustrative only and will be subject to change as part of detailed design development. Any changes will be limited to being within the constraints included in the Development Consent Order (application document reference TR010032/APP/3.1).  
2. All dimensions are in metres unless stated otherwise.

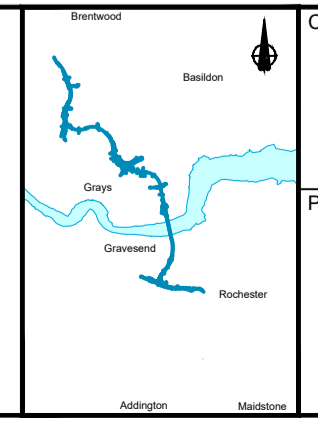
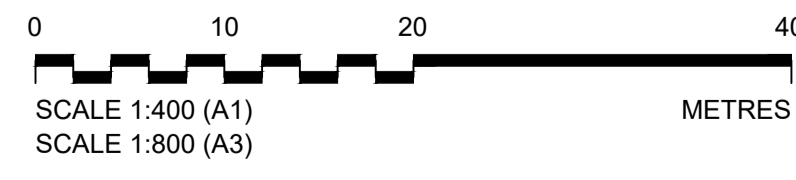

Project  
**LOWER THAMES CROSSING**

Status	Initial Status or WIP	Original Size	A1	Revision	P01.11
Application Document Number	TR010032/APP/2.9	Scale	1:400		
Drawing title	<b>OVERHEAD DIVERSION ROUTE REGULATION 5(2)(o) AND 6(2) PYLON LAYOUT</b>				
Drawing Number	HE540039-CJV-BOP-SZA_RX000000_-DR-CH-10800				

Rev	Status	Rev. Date	Purpose of revision	Drawn	Chk'd	Apprv'd
P01.11	SO	21/01/2021	DCO Application	MS	EB	TW

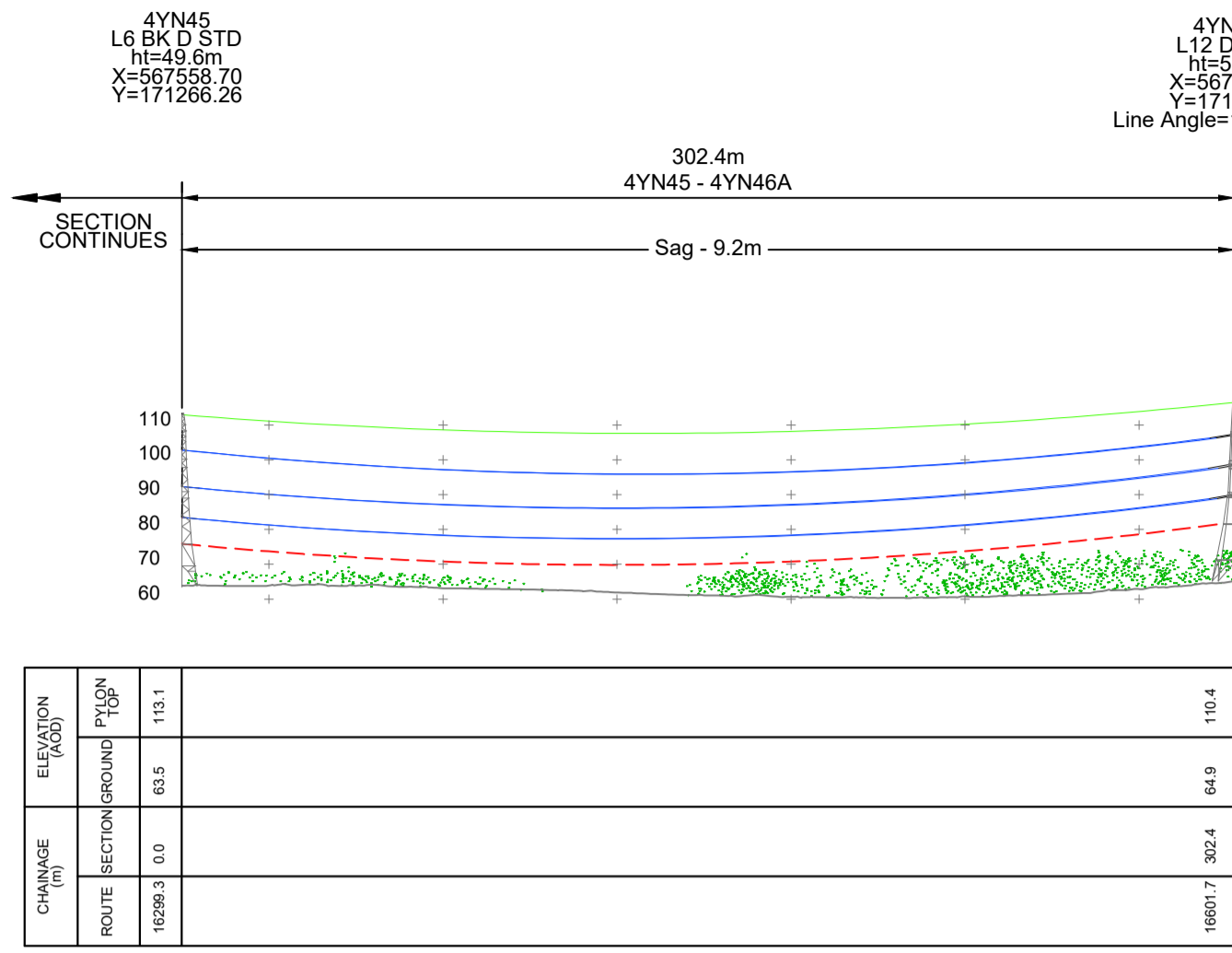

HORIZONTAL - SCALE 1:2000  
VERTICAL - NOT TO SCALE

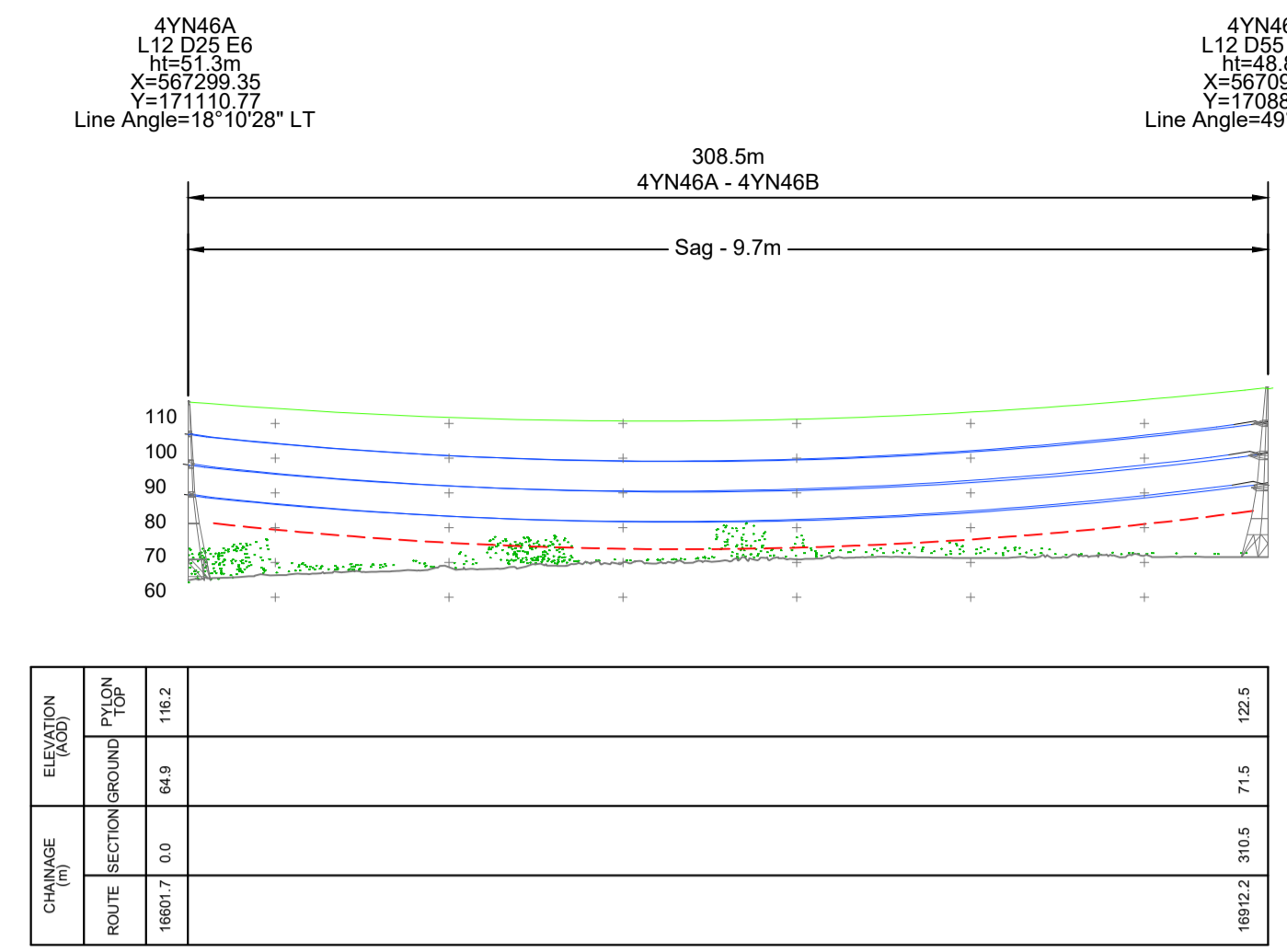

HORIZONTAL - SCALE 1:2000  
VERTICAL - NOT TO SCALE

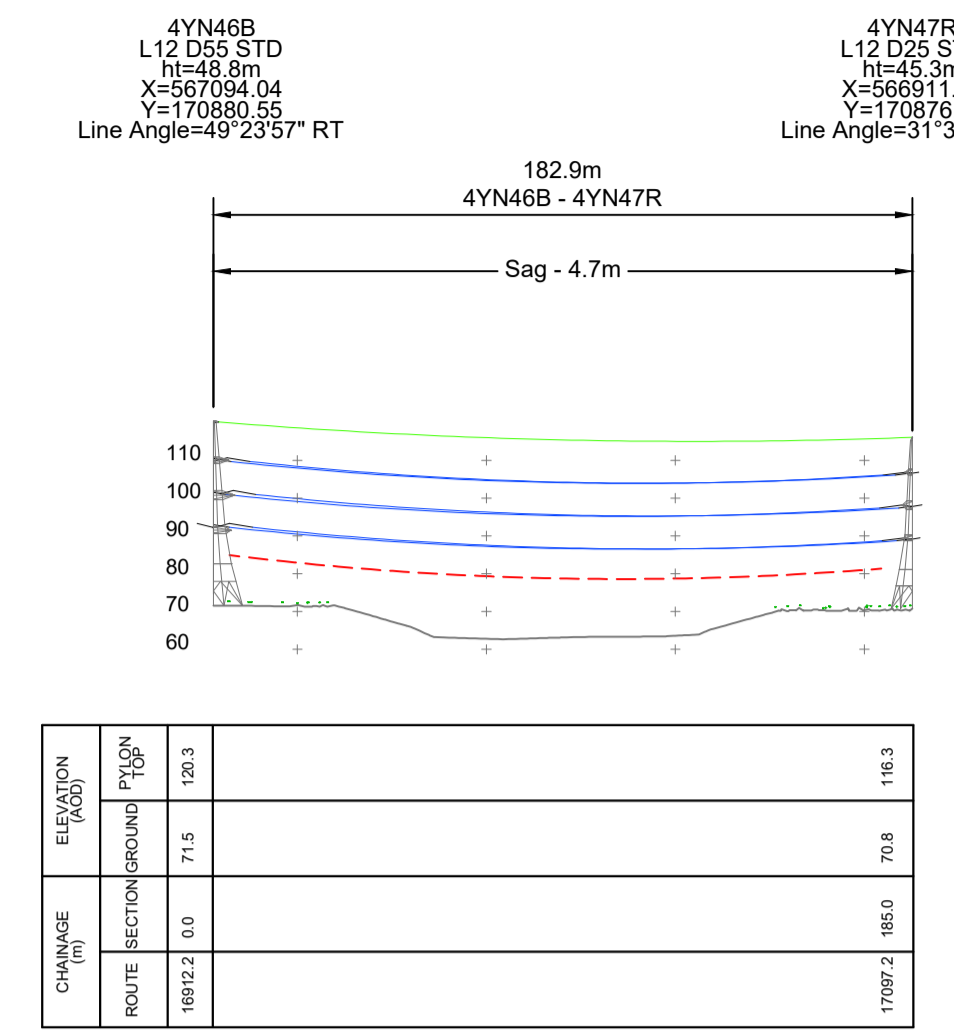

HORIZONTAL - SCALE 1:2000  
VERTICAL - NOT TO SCALE

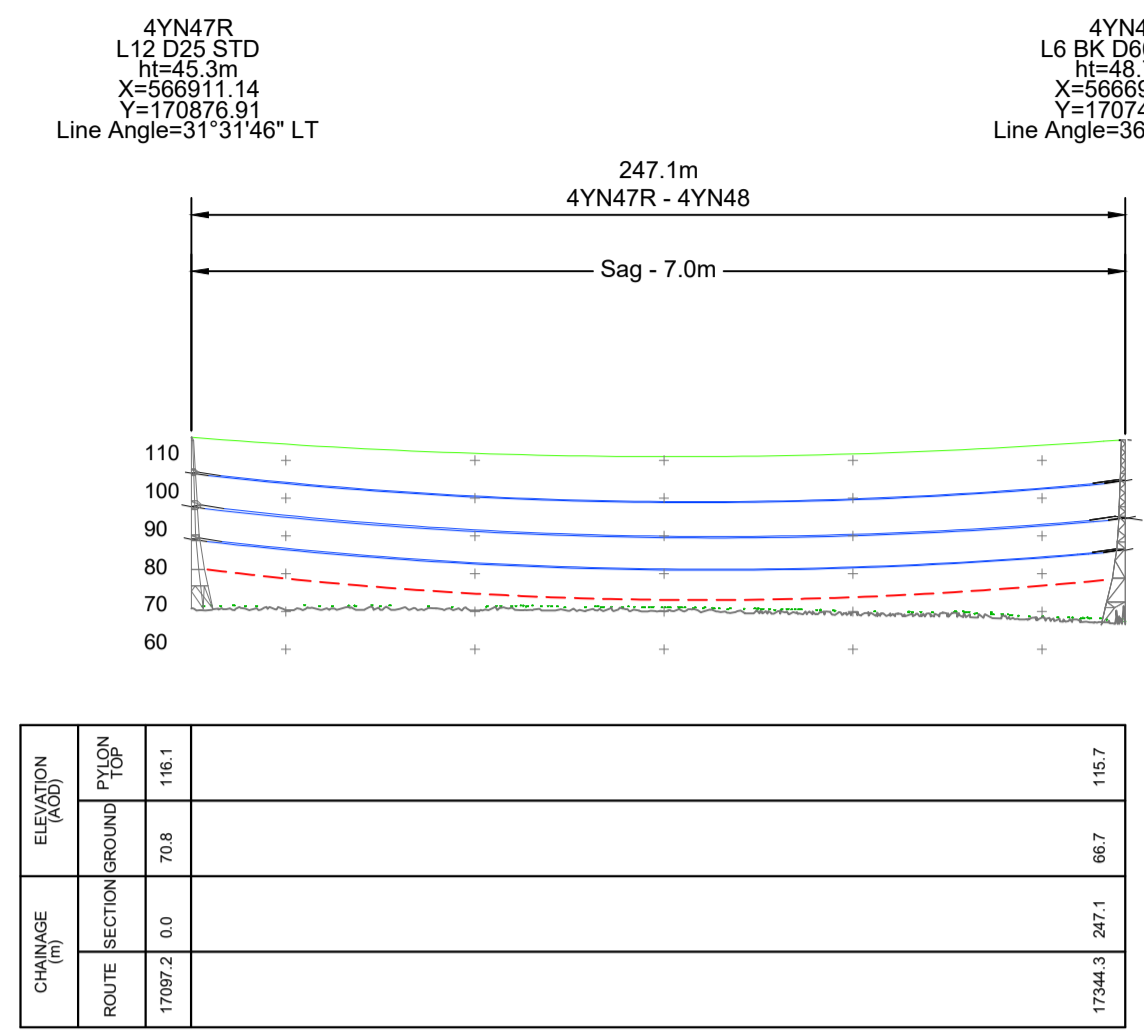

HORIZONTAL - SCALE 1:2000  
VERTICAL - NOT TO SCALE

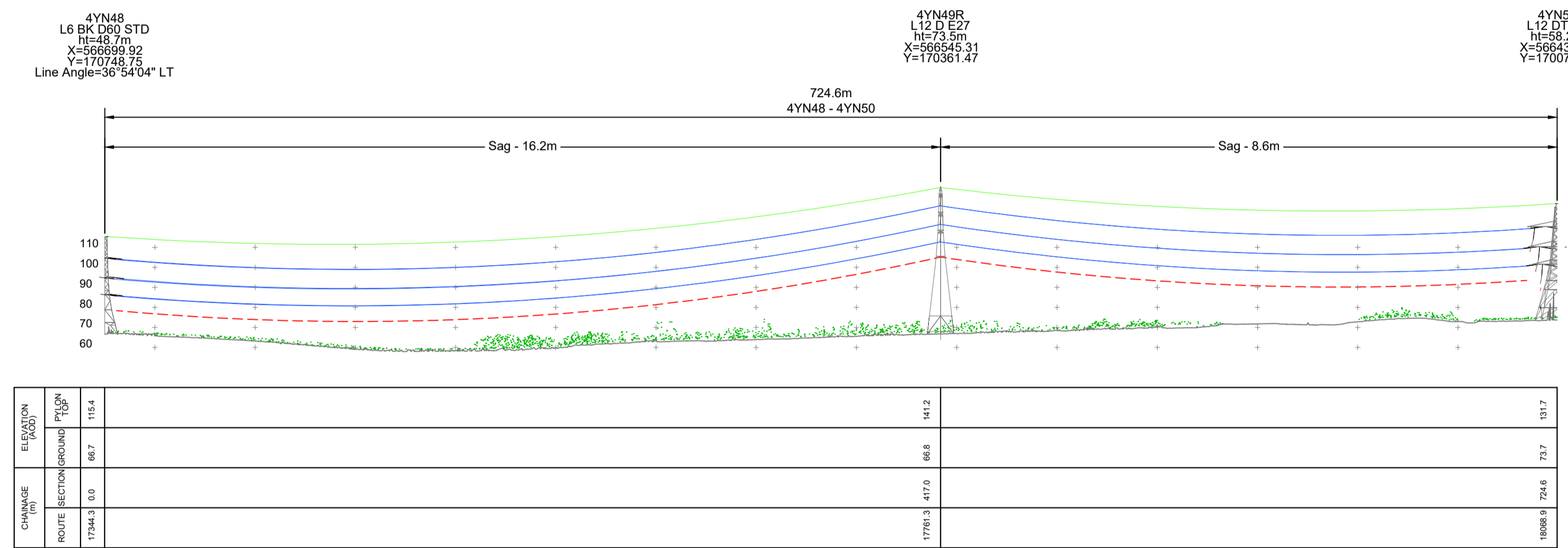

HORIZONTAL - SCALE 1:2000  
VERTICAL - NOT TO SCALE

Contains Ordnance Survey data. © Crown copyright and database rights 2022. Ordnance Survey 100030649

Rev	Status	Rev. Date	Purpose of revision	Drawn	Check'd	Apprv'd
P01.12	SO	12/09/2022	DCO Application	MS	EB	TW

- NOTES:
- The design and location of the structure is shown here for illustrative purposes only and will be subject to detailed design development in accordance with the provisions of the Development Consent Order (TR010032/APP/3.1).
  - For Environmental details refer to the Environmental Masterplan (TR010032/APP/6.2 Fig 2.4) and Environmental Constraints Plan (TR010032/APP/6.2 Fig 2.3) and associated drawings and documents. Drawings show engineering earthworks only. Landscape earthworks are not shown.
  - All dimensions in millimetres unless noted otherwise.
  - All levels are in metres and relate to Ordnance datum unless stated otherwise.
  - Works numbers are described in Schedule 1 (Authorised Development) of the Development Consent Order (TR010032/APP/3.1).
  - For pylon locations in plan refer to the Works Plans (TR010032/APP/2.6)

LEGEND:

- OPGW Earthwire
- Phase conductor
- Ground clearance line
- Ground Profile
- Vegetation

Pylon Labels:

4YN45  
L6 BK D STD  
49.9m  
X=567558.701  
Y=171266.26  
Line Angle=00°00'

4YN46A  
L12 D25 E6  
H=51.3m  
X=567299.35  
Y=171110.77  
Line Angle=18°10'28" LT

4YN46B  
L12 D25 E6  
H=51.3m  
X=567094.04  
Y=170830.55  
Line Angle=49°23'57" RT

4YN47R  
L12 D25 STD  
H=45.3m  
X=566911.14  
Y=170876.91  
Line Angle=31°31'46" LT

4YN48  
L6 BK D60 STD  
H=48.7m  
X=566699.92  
Y=170748.75  
Line Angle=36°54'04" LT

4YN49R  
L12 D E27  
H=51.5m  
X=566545.31  
Y=170361.47

4YN50  
L12 DT E9  
H=58.2m  
X=566432.29  
Y=170075.36

Section Labels:  
This drawing illustrates a line profile that is broken down by "Section" between each angle pylon e.g. 4YN45 - 4YN46A. Section length is also given.

0 50 100 200 METRES  
SCALE 1:2000 (A1)  
SCALE 1:4000 (A3)

Client: national highways

Project: LOWER THAMES CROSSING

Status	Initial Status or WIP	Original Size	Revision
Application Document Number	TR010032/APP/2.9	A1	P01.12
Drawing title	OVERHEAD DIVERSION ROUTE REGULATION 5(2)(o) AND 6(2) SHEET 1		
Drawing Number	HE540039-CJV-BOP-SZA_RX000000_-DR-CH-10801		

ZJ10  
L2 D60 E24  
51.2m  
X=566967.5  
Y=177490.7  
Line Angle=32°34'54" LT

118.3  
ZJ10 - ZJ11A

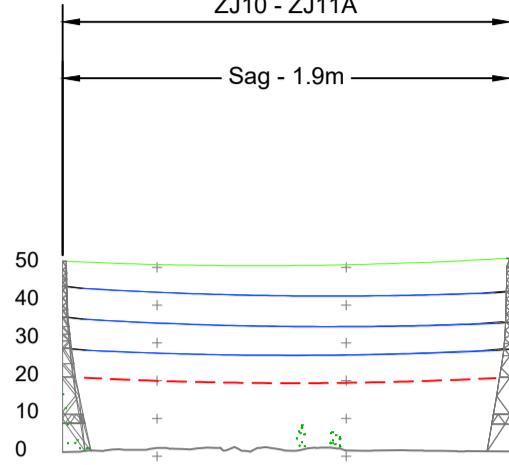

CHANGE (m)	ELEVATION (AOD)	
	ROUTE SECTION/GROUND	PLYON TOP
37894.4	0.0	1.1
37777.7	18.3	1.3
		52.4

HORIZONTAL - SCALE 1:2000  
VERTICAL - NOT TO SCALE

ZJ11A  
L8(c) D30 E7.3  
51.1m  
X=567005.5  
Y=177632.2  
Line Angle=29°6'58" LT

ZJ11A  
L8(c) D30 E7.3  
51.1m  
X=567005.5  
Y=177632.2  
Line Angle=29°6'58" LT

ZJ11B  
L8(c) D E4.9  
51.3m  
X=566963.1  
Y=177835.3

561.8  
ZJ11A - ZJ11C

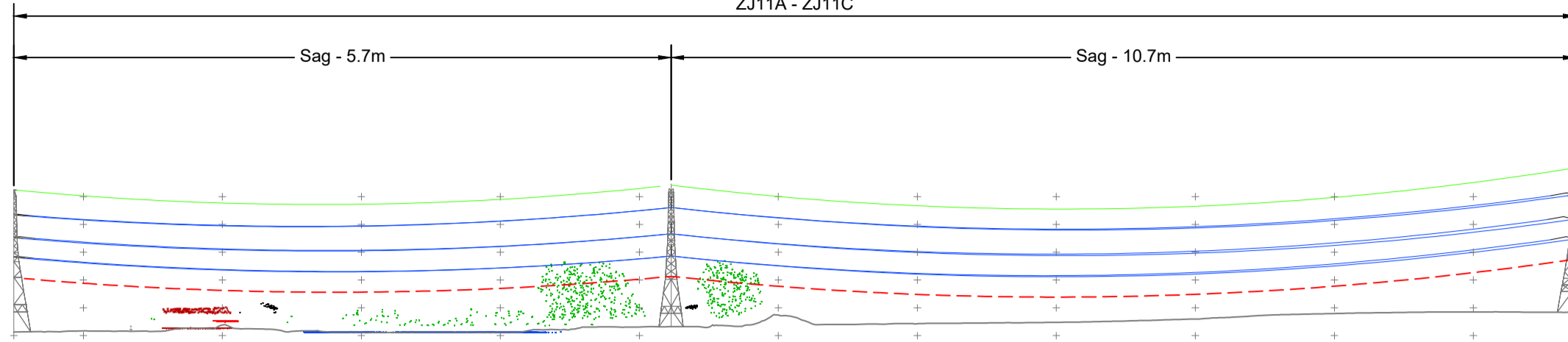

CHANGE (m)	ELEVATION (AOD)	
	ROUTE SECTION/GROUND	PLYON TOP
37777.7	0.0	1.3
38044.1	206.4	3.2
		54.5
38395.5	301.8	6.3
		60.1

HORIZONTAL - SCALE 1:2000  
VERTICAL - NOT TO SCALE

ZJ11C  
L8(c) D60 E7.3  
51.8m  
X=566906.4  
Y=178154.8  
Line Angle=59°1'18" RT

ZJ11C  
L8(c) D60 E7.3  
51.8m  
X=566906.4  
Y=178154.8  
Line Angle=59°1'18" RT

ZJ12R  
L8(c) D60 E7.3  
51.8m  
X=567062.9  
Y=178236.8  
Line Angle=53°21'48" LT

213.1  
ZJ11C - ZJ12R

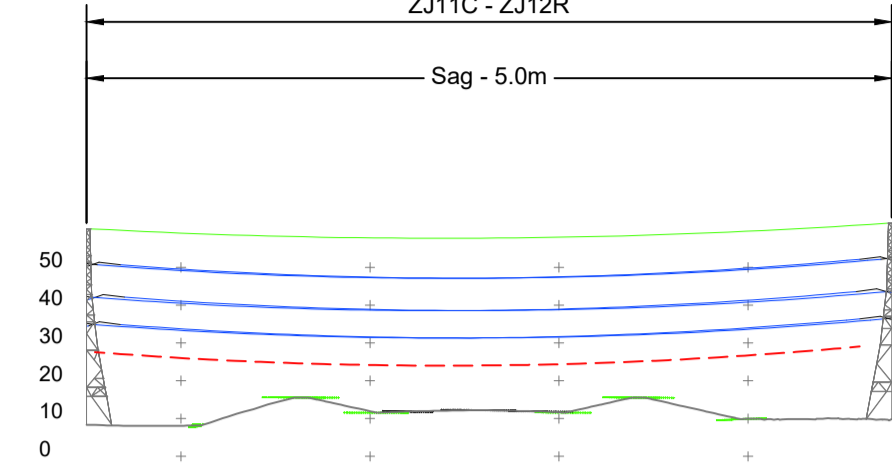

CHANGE (m)	ELEVATION (AOD)	
	ROUTE SECTION/GROUND	PLYON TOP
38339.5	0.0	8.3
38552.6	213.1	8.6
		61.6

HORIZONTAL - SCALE 1:2000  
VERTICAL - NOT TO SCALE

ZJ12R  
L8(c) D60 E7.3  
51.8m  
X=567062.9  
Y=178236.8  
Line Angle=53°21'48" LT

ZJ13  
L2 D E24  
48.9m  
X=567037  
Y=178632.5

ZJ14R  
L8(c) D E11  
57.4m  
X=567007.8  
Y=178987.7

1421.8  
ZJ12R - ZJ16

ZJ15  
L2 D E8  
44m  
X=566976  
Y=179374.3

ZJ16  
L2 D60 STD  
42.9m  
X=566949.1  
Y=179713.3  
Line Angle=52°7'45" RT

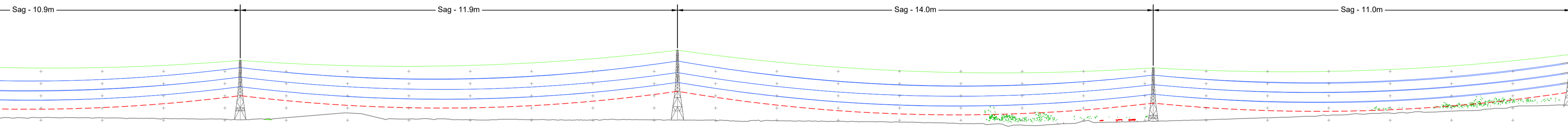

CHANGE (m)	ELEVATION (AOD)	
	ROUTE SECTION/GROUND	PLYON TOP
38552.6	0.0	9.8
38900.1	337.5	10.4
		60.3
39246.5	675.9	10.2
		60.6
39594.4	1017.8	10.0
		60.0
39941.5	1451.8	22.4
		66.3

HORIZONTAL - SCALE 1:2000  
VERTICAL - NOT TO SCALE

Contains Ordnance Survey data. © Crown copyright and database rights 2022. Ordnance Survey 100030649					
P01.11	SO	21/01/2021	DCO Application	MS	EB TW
Rev	Status	Rev. Date	Purpose of revision	Drawn	Chk'd Apprv'd

- NOTES:
- The proposed works shown are illustrative only and will be subject to change as part of the detailed design development. Any changes will be limited to being within the constraints included in the Development Consent Order (application document reference TR010032/APP/2.9).
  - These plans should be read in conjunction with Schedule 1 (Authorised Development) of the Development Consent Order (application document reference TR010032/APP/3.1).
  - For Environmental details refer to the Environmental Masterplan (application document TR010032/APP/6.2 Fig. 2.4) and Environmental Constraints Plan (TR010032/APP/6.2 Fig. 2.3) and associated drawings and documents.
  - These plans show engineering earthworks only and landscape earthworks are not shown.
  - All dimensions are in millimetres unless stated otherwise.
  - All levels are in metres and relate to Ordnance datum unless stated otherwise.

LEGEND:

- OPGW Earthwire
- Phase conductor
- Ground clearance line
- Ground Profile
- Vegetation

Pylon Labels:

- 4YN45 Pylon designation
- L6 BK D STD Pylon type
- 49.9m Pylon height
- X=567558.701 Pylon position
- Y=171266.26 Pylon deviation
- LT Left
- RT Right

Section Labels:

This drawing illustrates a line profile that is broken down by "Section" between each angle pylon e.g. 4YN45 - 4YN46A. Section length is also given.

0 50 100 200 METRES

SCALE 1:2000 (A1)  
SCALE 1:4000 (A3)

Client

national highways

Project

LOWER THAMES CROSSING

Status: Initial Status or WIP

Application Document Number: TR010032/APP/2.9

Drawing title: OVERHEAD DIVERSION ROUTE REGULATION 5(2)(o) AND 6(2) SHEET 2

Drawing Number: HE540039-CJV-BOP-SZA\_RX000000\_-DR-CH-10802

Original Size	A1	Revision	P01.11
Scale	AS SHOWN		

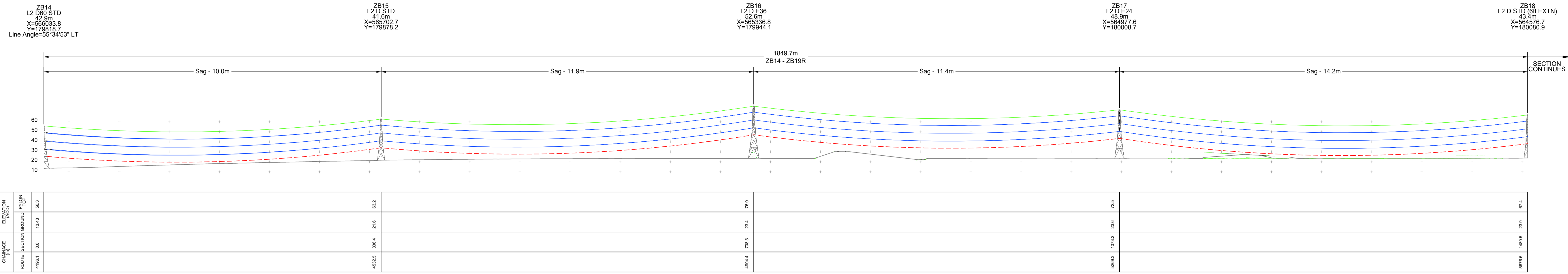

HORIZONTAL - SCALE 1:2000  
VERTICAL - NOT TO SCALE

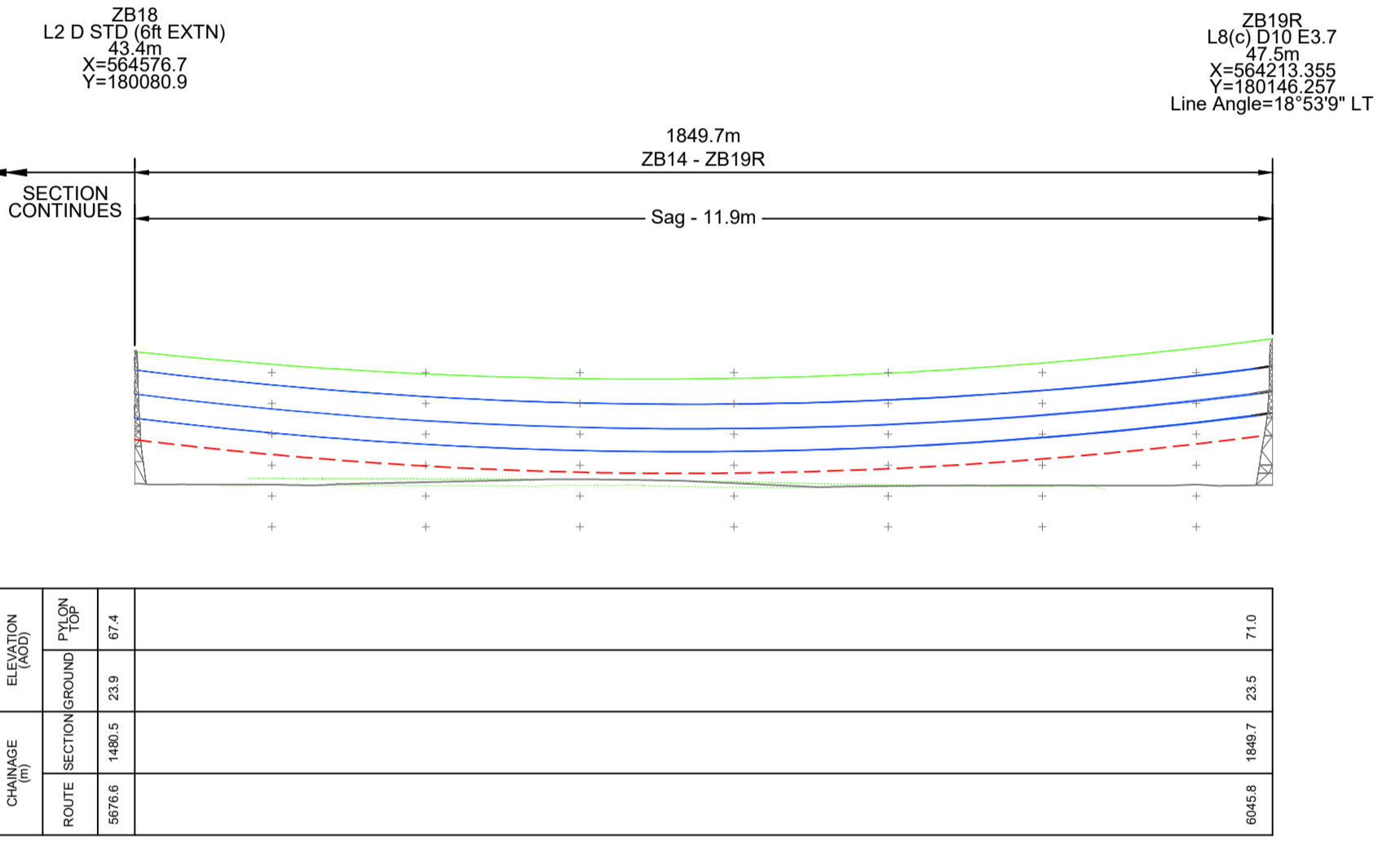

HORIZONTAL - SCALE 1:2000  
VERTICAL - NOT TO SCALE

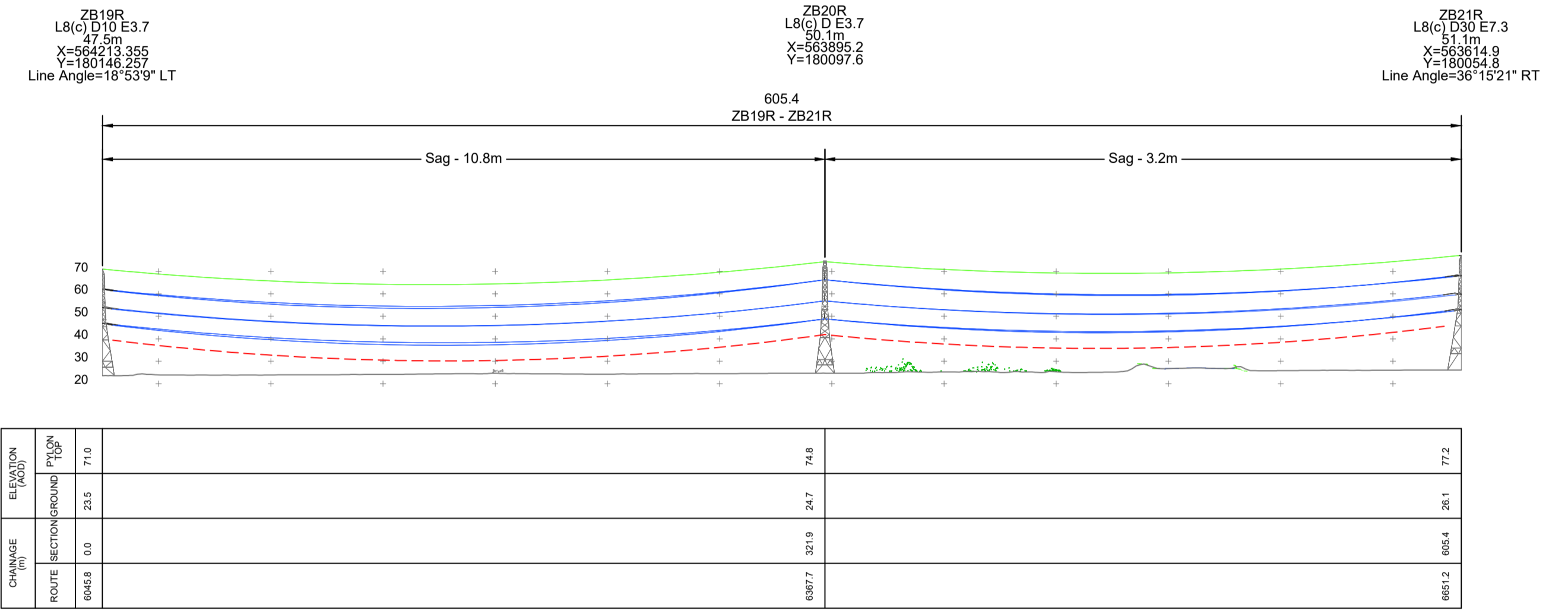

HORIZONTAL - SCALE 1:2000  
VERTICAL - NOT TO SCALE

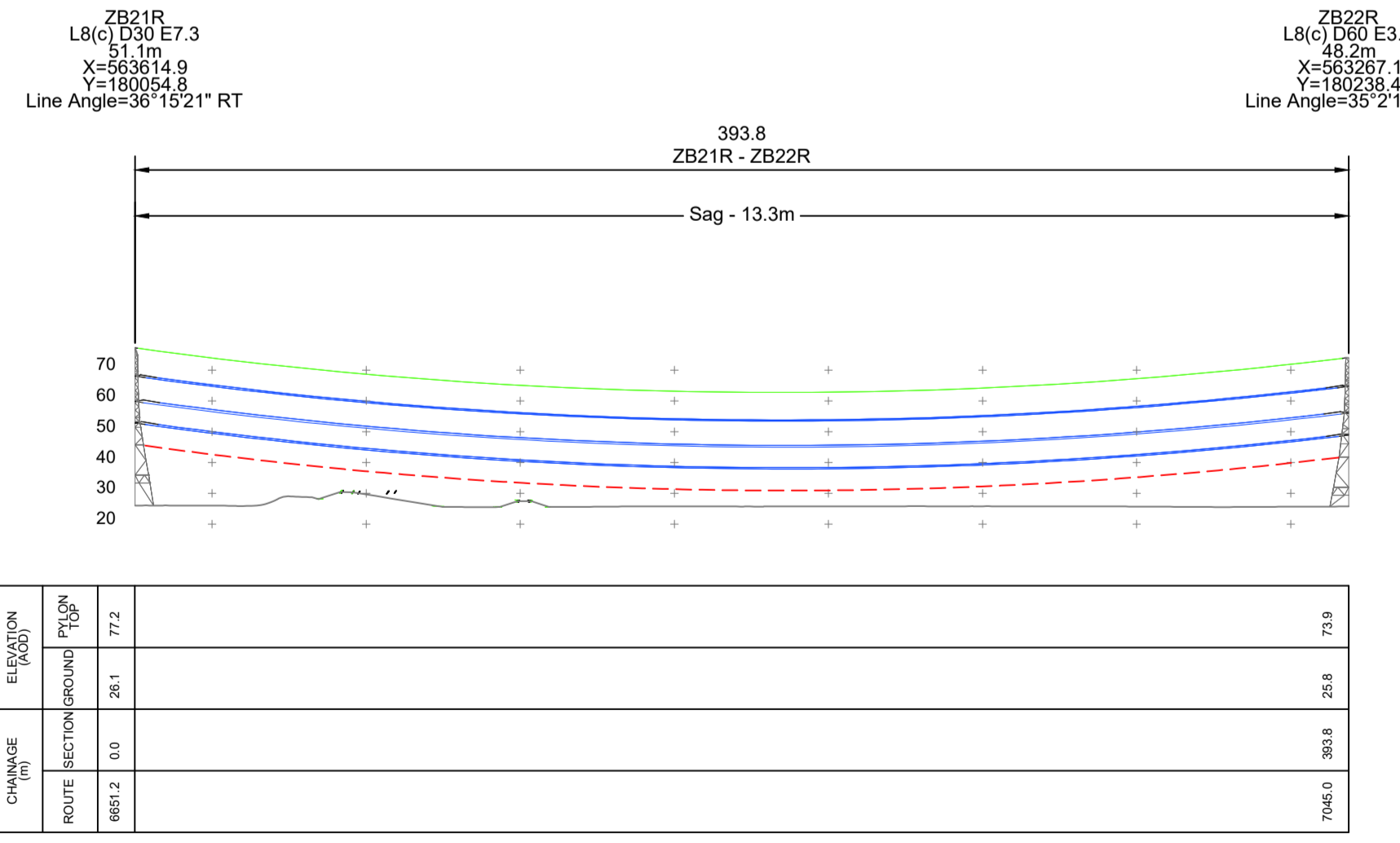

HORIZONTAL - SCALE 1:2000  
VERTICAL - NOT TO SCALE

- NOTES:**
- The proposed works shown are illustrative only and will be subject to change as part of detailed design development. Any changes will be limited to being within the constraints included in the Development Consent Order (application document reference TR010032/APP/3.1).
  - These plans should be read in conjunction with Schedule 1 (Authorised Development) of the Development Consent Order (application document reference TR010032/APP/3.1).
  - For Environmental details refer to the Environmental Masterplan (application document TR010032/APP/6.2 Fig. 2.4) and environmental Constraints Plan (TR010032/APP/6.2 Fig. 2.3) and associated drawings and documents.
  - These plans show engineering earthworks only and landscape earthworks are not shown.
  - All dimensions are in millimetres unless stated otherwise.
  - All levels are in metres and relate to Ordnance datum unless stated otherwise.

- LEGEND:**
- OPGW Earthwire
  - Phase conductor
  - Ground clearance line
  - Ground Profile
  - Vegetation
- Pylon Labels:**
- 4YN45 Pylon designation
  - L6 BK D STD Pylon type
  - 49.9m Pylon height
  - X=567558.701 Pylon position
  - Y=171266.26 Pylon position
  - Line Angle=00°00' Pylon deviation
  - LT Left
  - RT Right
- Section Labels:**
- This drawing illustrates a line profile that is broken down by "Section" between each angle pylon e.g. 4YN45 - 4YN46A.
  - Section length is also given.

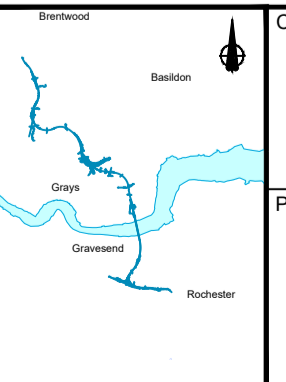
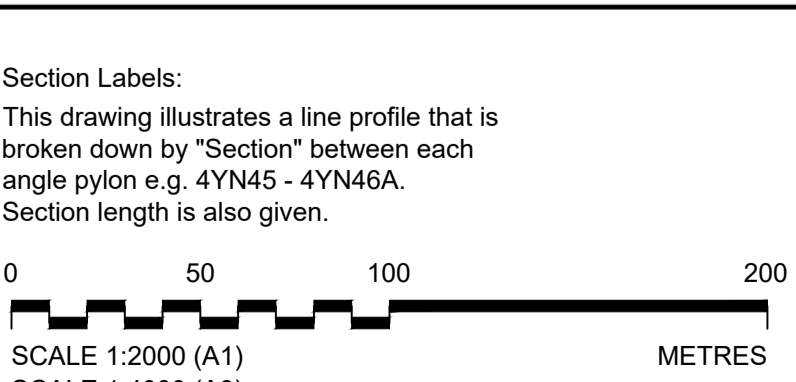

**national highways**

**LOWER THAMES CROSSING**

Status	Initial Status or WIP	Original Size	A1	Revision	P01.11
Application Document Number	TR010032/APP/2.9	Scale	AS SHOWN		
Drawing title	OVERHEAD DIVERSION ROUTE REGULATION 5(2)(c) AND 6(2) SHEET 3				
Drawing Number	HE540039-CJV-BOP-SZA_RX000000_-DR-CH-10803				

P01.11	SO	21/01/2021	DCO Application	MS	EB	TW
Rev	Status	Rev. Date	Purpose of revision	Drawn	Chk'd	Apprv'd

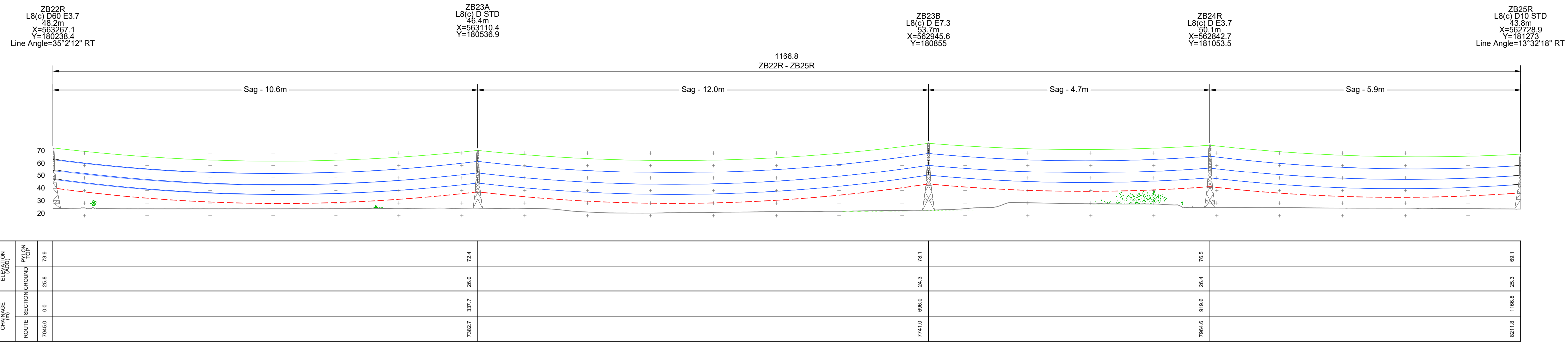

HORIZONTAL - SCALE 1:2000  
VERTICAL - NOT TO SCALE

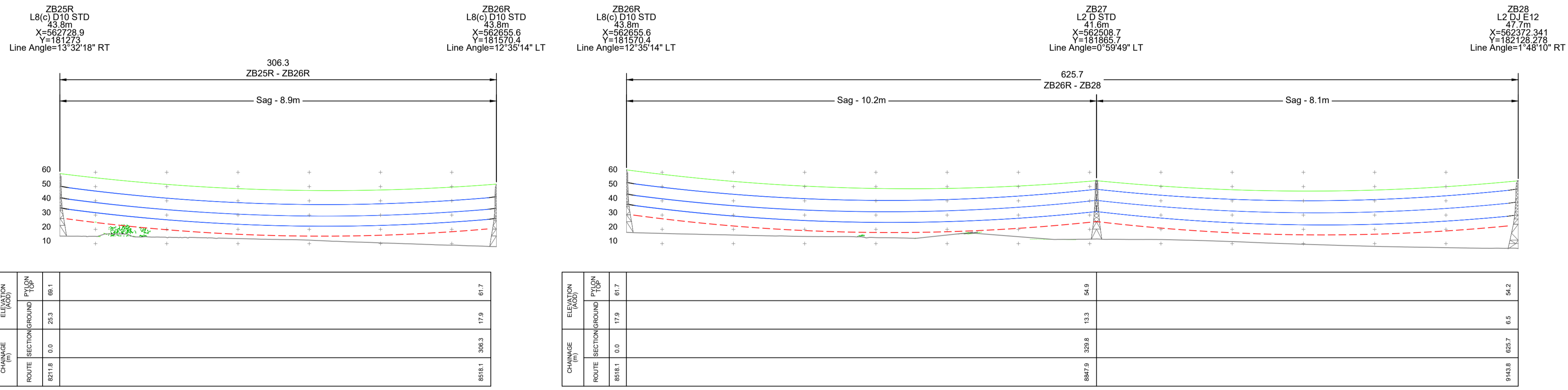

HORIZONTAL - SCALE 1:2000  
VERTICAL - NOT TO SCALE

HORIZONTAL - SCALE 1:2000  
VERTICAL - NOT TO SCALE

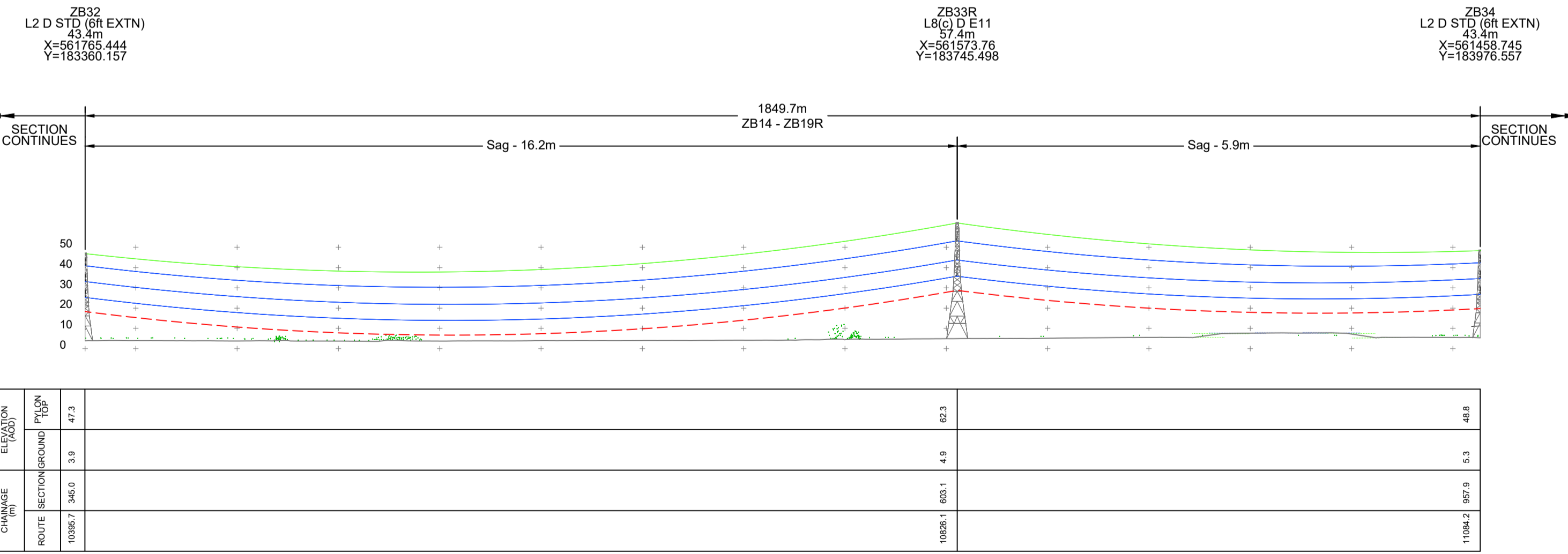

HORIZONTAL - SCALE 1:2000  
VERTICAL - NOT TO SCALE

Contains Ordnance Survey data. © Crown copyright and database rights 2022. Ordnance Survey 100038649				
P01.11	SO	21/01/2021	DCO Application	MS EB TW
Rev	Status	Rev. Date	Purpose of revision	Drawn Check'd Apprv'd

- NOTES:**
- The proposed works shown are illustrative only and will be subject to change as a part of detailed design development. Any changes will be limited to being within the constraints included in the Development Consent Order (application document reference TR010032/APP/2.9).
  - These plans should be read in conjunction with Schedule 1 (Authorised Development) of the Development Consent Order (application document reference TR010032/APP/3.1).
  - For Environmental details refer to the Environmental Masterplan (application document TR010032/APP/6.2 Fig. 2.4) and Environmental Constraints Plan (TR010032/APP/6.2 Fig. 2.3) and associated drawings and documents.
  - These plans show engineering earthworks only and landscape earthworks are not shown.
  - All dimensions are in millimetres unless stated otherwise.
  - All levels are in metres and relate to Ordnance datum unless stated otherwise.

- LEGEND:**
- OPGW Earthwire
  - Phase conductor
  - Ground clearance line
  - Ground Profile
  - Vegetation
- Pylon Labels:**
- 4YN45 Pylon designation  
L6 BK D STD Pylon type  
49.9m Pylon height  
X=567558.701 Pylon position  
Y=171266.26  
Line Angle=00°00'
- LT Left  
RT Right
- Section Labels:**
- This drawing illustrates a line profile that is broken down by "Section" between each angle pylon e.g. 4YN45 - 4YN46A. Section length is also given.
- 0 50 100 200 METRES  
SCALE 1:2000 (A1)  
SCALE 1:4000 (A3)

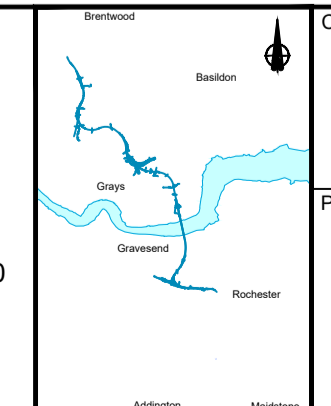

**national highways**

Client

Project

**LOWER THAMES CROSSING**

Status	Initial Status or WIP	Original Size	A1	Revision	P01.11
Application Document Number	TR010032/APP/2.9	Scale	AS SHOWN		
Drawing title	OVERHEAD DIVERSION ROUTE REGULATION 5(2)(o) AND 6(2) SHEET 4				
Drawing Number	HE540039-CJV-BOP-SZA_RX000000_-DR-CH-10804				

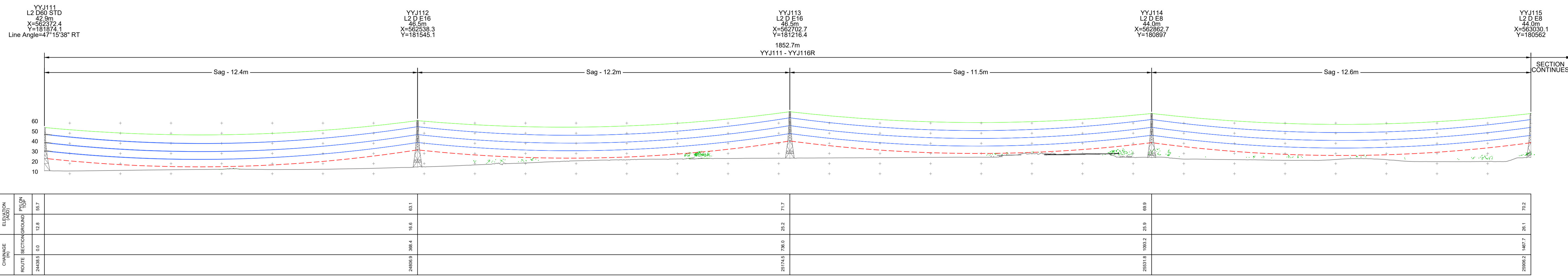

HORIZONTAL - SCALE 1:2000  
VERTICAL - NOT TO SCALE

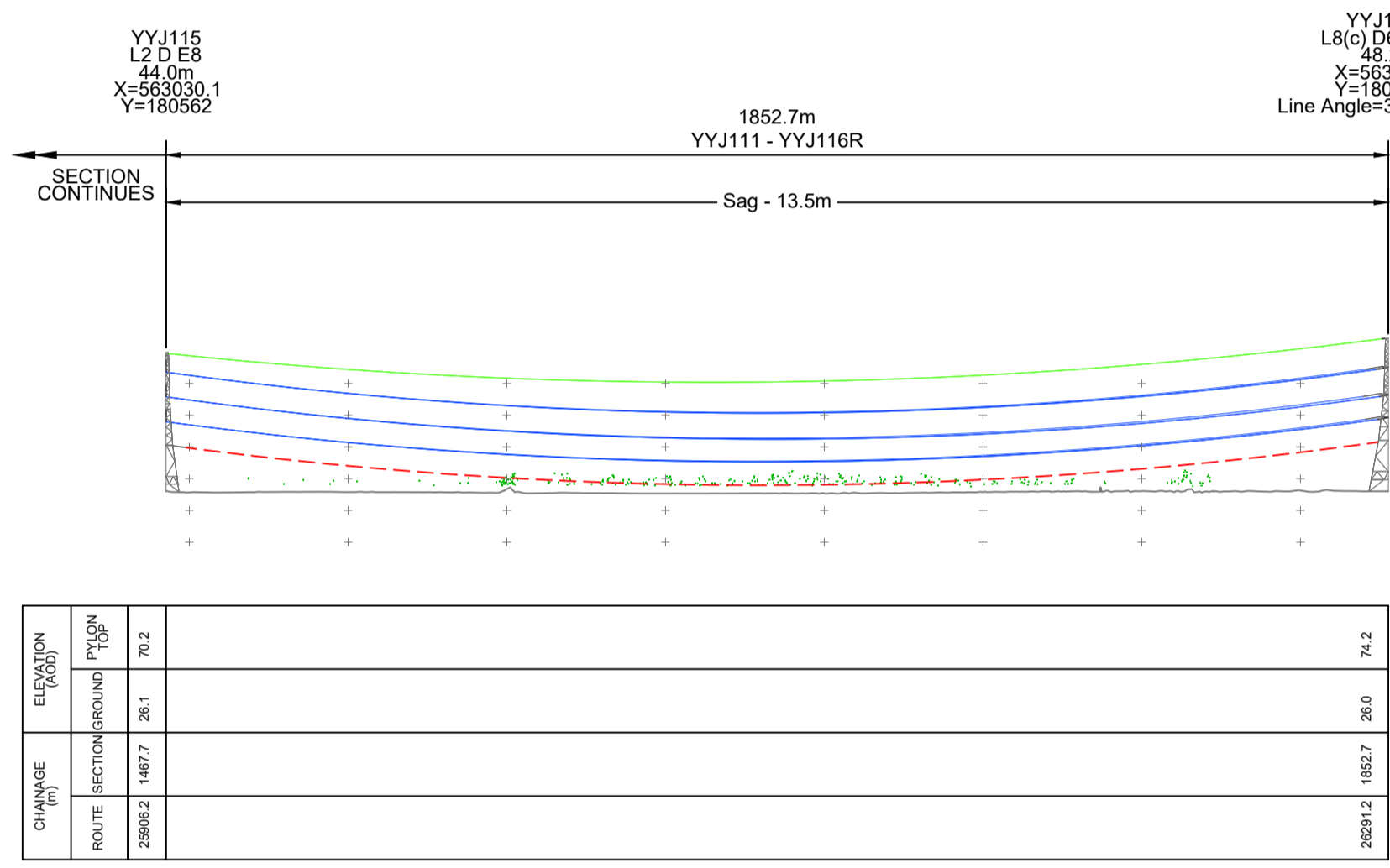

HORIZONTAL - SCALE 1:2000  
VERTICAL - NOT TO SCALE

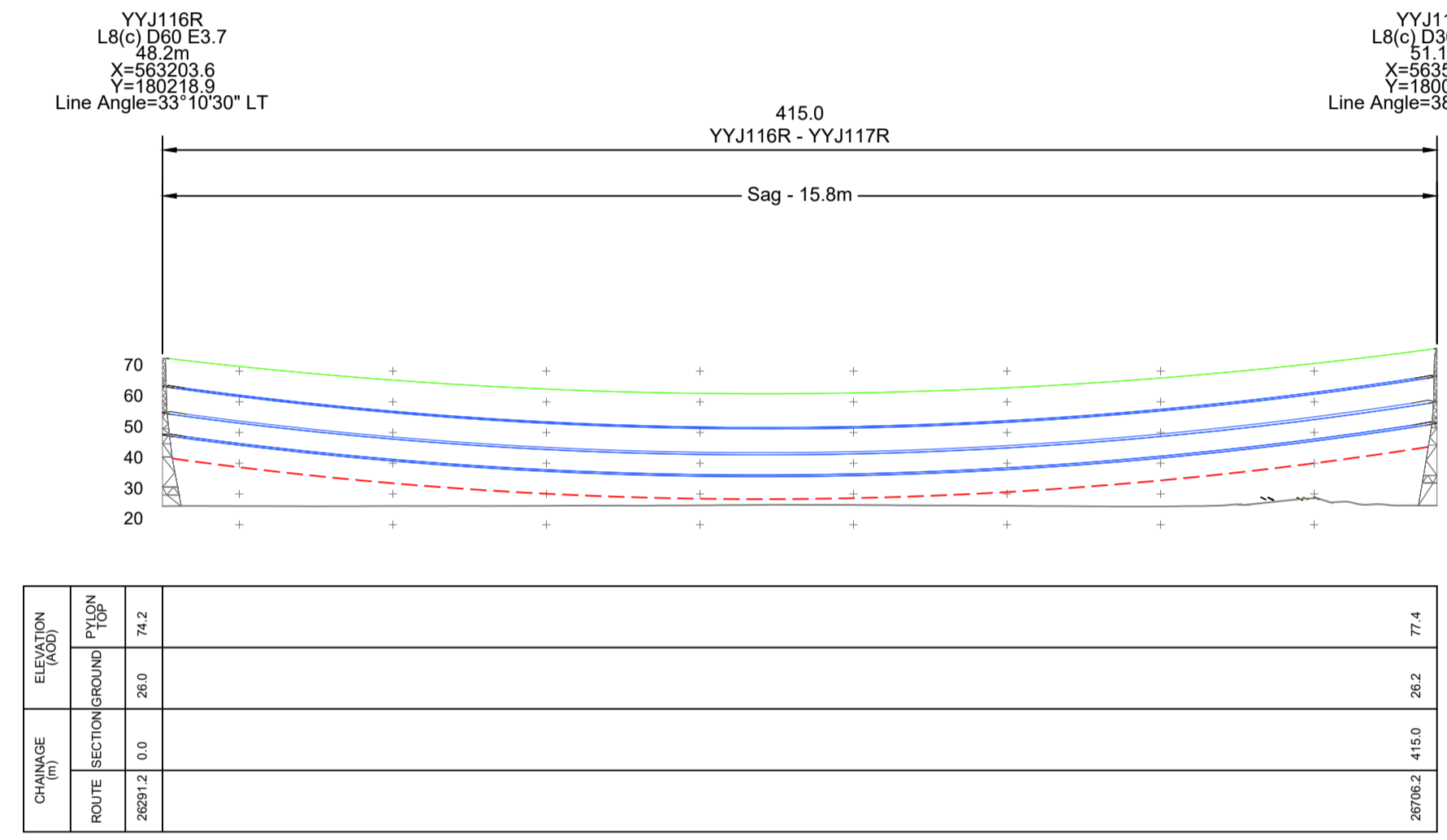

HORIZONTAL - SCALE 1:2000  
VERTICAL - NOT TO SCALE

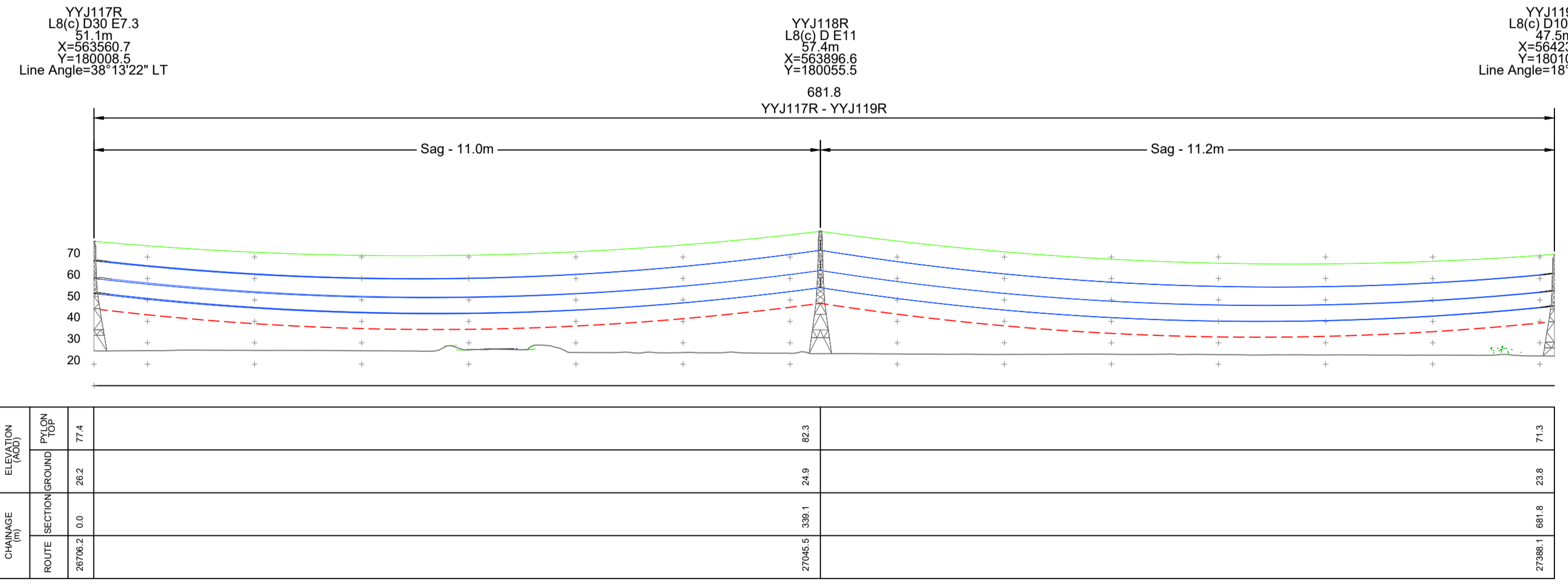

HORIZONTAL - SCALE 1:2000  
VERTICAL - NOT TO SCALE

NOTES:

- The proposed works shown are illustrative only and will be subject to change as part of the detailed design development. Any changes will be limited to being within the constraints included in the Development Consent Order (application document reference TR010032/APP/3.1).
- These plans should be read in conjunction with Schedule 1 (Authorised Development) of the Development Consent Order (application document reference TR010032/APP/3.1).
- For Environmental details refer to the Environmental Masterplan (application document TR010032/APP/6.2 Fig. 2.4) and Environmental Constraints Plan (TR010032/APP/6.2 Fig. 2.3) and associated drawings and documents.
- These plans show engineering earthworks only and landscape earthworks are not shown.
- All dimensions are in millimetres unless stated otherwise.
- All levels are in metres and relate to Ordnance datum unless stated otherwise.

LEGEND:

- OPGW Earthwire
- Phase conductor
- Ground clearance line
- Ground Profile
- Vegetation

- Pylon Labels:
- 4YN45 Pylon designation
  - L6 BK D STD Pylon type
  - 49.9m Pylon height
  - X=567558.701 Pylon position
  - Y=171266.26 Pylon deviation
  - LT Left
  - RT Right

Section Labels:  
This drawing illustrates a line profile that is broken down by "Section" between each angle pylon e.g. 4YN45 - 4YN46A. Section length is also given.

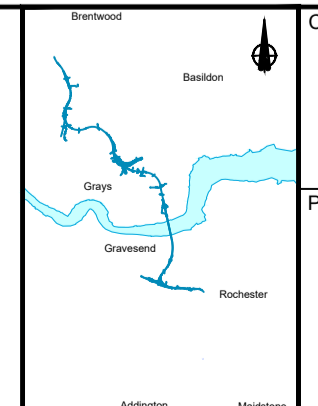
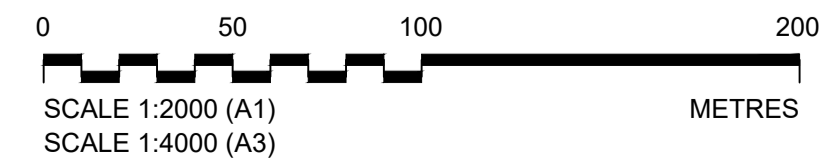

LOWER THAMES CROSSING

Status	Initial Status or WIP	Original Size	A1	Revision	P01.11
Application Document Number	TR010032/APP/2.9	Scale	AS SHOWN		
Drawing title	OVERHEAD DIVERSION ROUTE REGULATION 5(2)(c) AND 6(2) SHEET 5				
Drawing Number	HE540039-CJV-BOP-SZA_RX000000_-DR-CH-10805				

Rev	Status	Rev. Date	Purpose of revision	Drawn	Check'd	Apprv'd
P01.11	SO	21/01/2021	DCO Application	MS	EB	TW

YYJ119R  
L8(C) D10 E3.7  
47.5m  
X=564236.0  
Y=180102.3  
Line Angle=18°13'17" RT

YYJ120  
L2 D E52  
57.5m  
X=564439.3  
Y=180062.5

YYJ121  
L2 E10 E48  
56.5m  
X=564970.7  
Y=179869.8  
Line Angle=0°05'7" LT

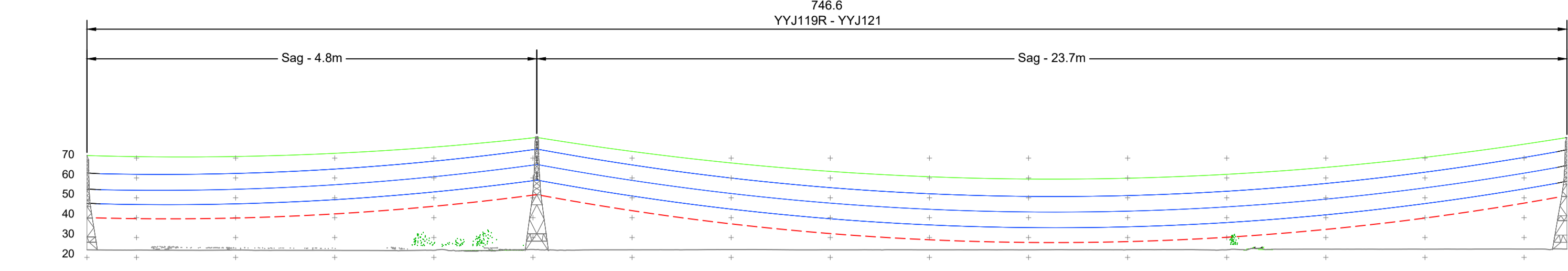

CHANGE (m)	ROUTE SECTION/ROUND	ELEVATION (AOD)	
		GROUND	TOP
27386.1	0.0	23.8	71.3
27616.0	206.6	23.8	81.3
28136.7	146.6	24.2	80.7

HORIZONTAL - SCALE 1:2000  
VERTICAL - NOT TO SCALE

YYJ121  
L2 E10 E48  
56.5m  
X=564970.7  
Y=179869.8  
Line Angle=0°05'7" LT

YYJ122  
L2 D E16  
46.5m  
X=565330.1  
Y=179904.8

YYJ123  
L2 D E8  
44.0m  
X=565695.9  
Y=179838.7

YYJ124  
L2 D60 M12  
39.2m  
X=566006.7  
Y=179781.3  
Line Angle=54°52'47" RT

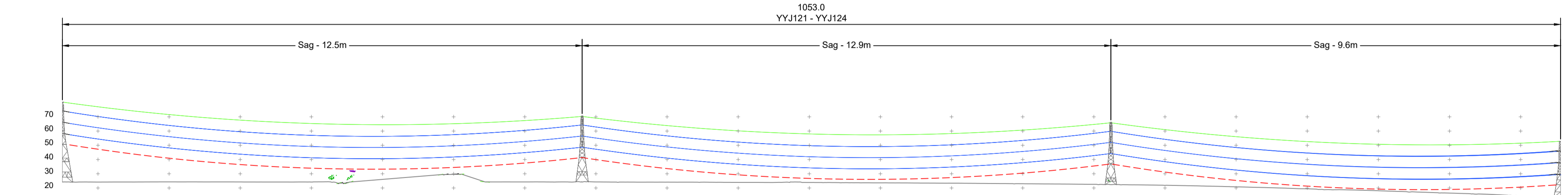

CHANGE (m)	ROUTE SECTION/ROUND	ELEVATION (AOD)	
		GROUND	TOP
28136.7	0.0	24.2	80.7
28500	365.3	24.2	70.6
28671.6	727.0	22.3	66.4
29187.7	1053.0	13.6	52.8

HORIZONTAL - SCALE 1:2000  
VERTICAL - NOT TO SCALE

Contains Ordnance Survey data. © Crown copyright and database rights 2022. Ordnance Survey 100030649

P01.11	SO	21/01/2021	DCO Application	MS	EB	TW
Rev	Status	Rev. Date	Purpose of revision	Drawn	Check'd	Apprv'd

**NOTES:**

- The proposed works shown are illustrative only and will be subject to change as part of detailed design development. Any changes will be limited to being within the constraints included in the Development Consent Order (application document reference TR010032/APP/3.1).
- These plans should be read in conjunction with Schedule 1 (Authorised Development) of the Development Consent Order (application document reference TR010032/APP/3.1).
- For Environmental details refer to the Environmental Masterplan (application document TR010032/APP/3.2 Fig. 2.4) and environmental Constraints Plan (TR010032/APP/3.1).
- These plans show engineering earthworks only and landscape earthworks are not shown.
- All dimensions are in millimetres unless stated otherwise.
- All levels are in metres and relate to Ordnance datum unless stated otherwise.

**LEGEND:**

- OPGW Earthwire
- Phase conductor
- Ground clearance line
- Ground Profile
- Vegetation

**Pylon Labels:**

4YN45  
L6 BK D STD  
49.9m  
X=567558.701  
Y=171266.26  
Line Angle=00°00'

4YN45  
L6 BK D STD  
49.9m  
X=567558.701  
Y=171266.26  
Line Angle=00°00'

LT  
RT

Pylon designation  
Pylon type  
Pylon height  
Pylon position  
Pylon deviation  
Left  
Right

**Section Labels:**  
This drawing illustrates a line profile that is broken down by "Section" between each angle pylon e.g. 4YN45 - 4YN46A. Section length is also given.

0 50 100 200  
SCALE 1:2000 (A1)  
SCALE 1:4000 (A3)  
METRES

Client: national highways

Project: LOWER THAMES CROSSING

Status	Initial Status or WIP	Original Size	A1	Revision	P01.11
Application Document Number	TR010032/APP/2.9	Scale	AS SHOWN		
Drawing title	OVERHEAD DIVERSION ROUTE REGULATION 5(2)(o) AND 6(2) SHEET 6				
Drawing Number	HE540039-CJV-BOP-SZA_RX000000_-DR-CH-10806				

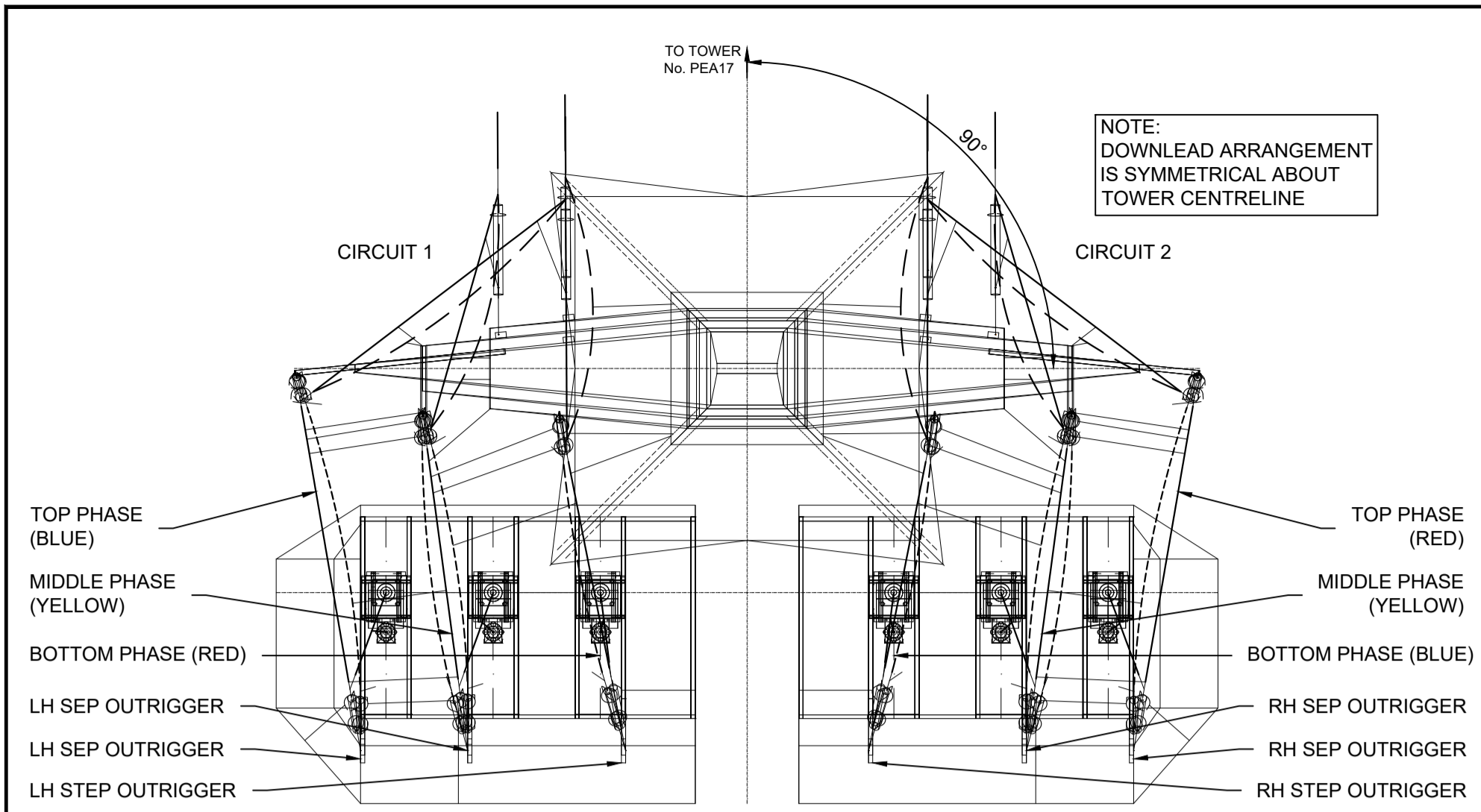

PLAN  
1:100

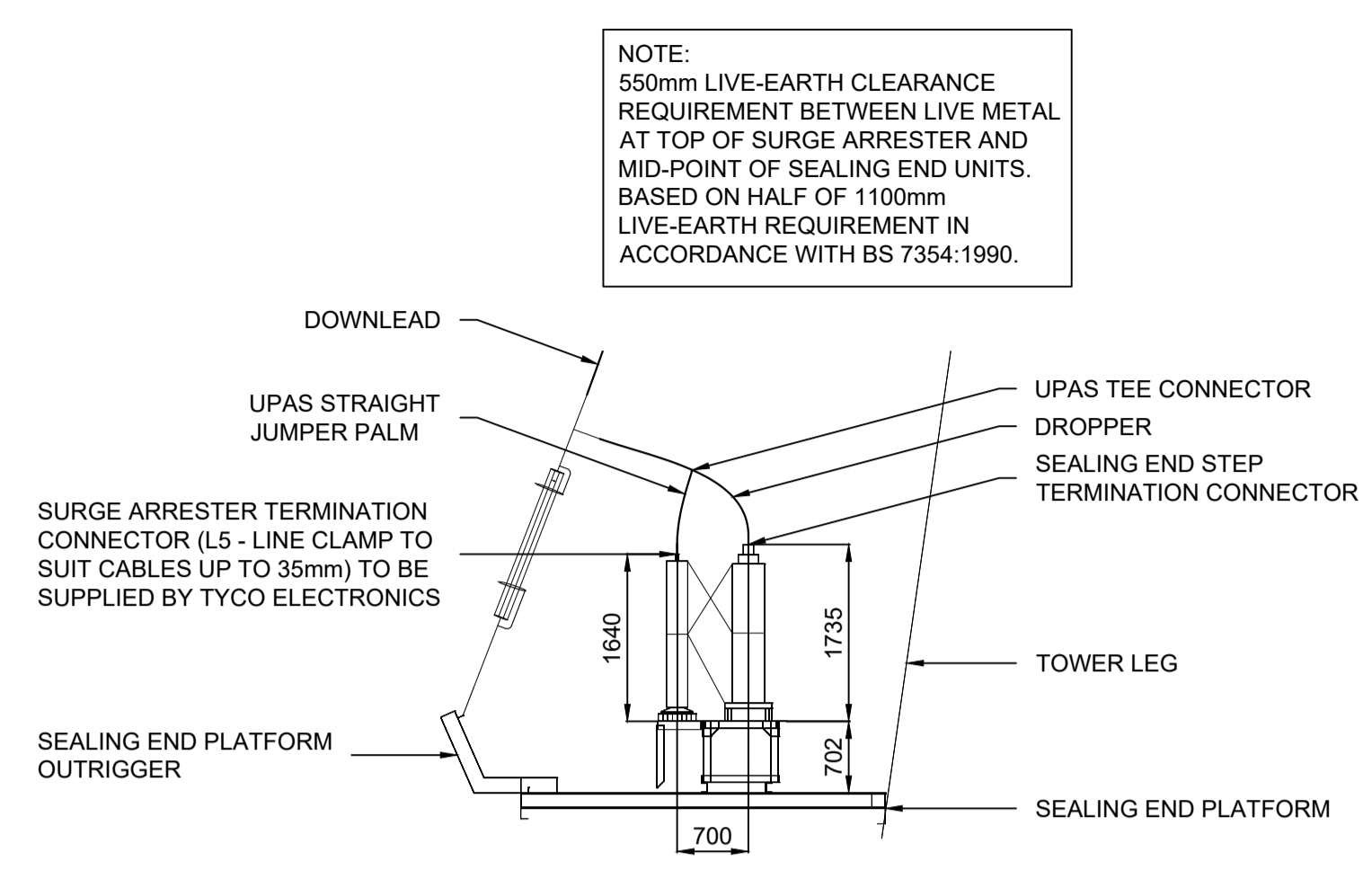

TYPICAL ENLARGED VIEW OF SEALING  
END AND SURGE ARRESTERS  
1:100

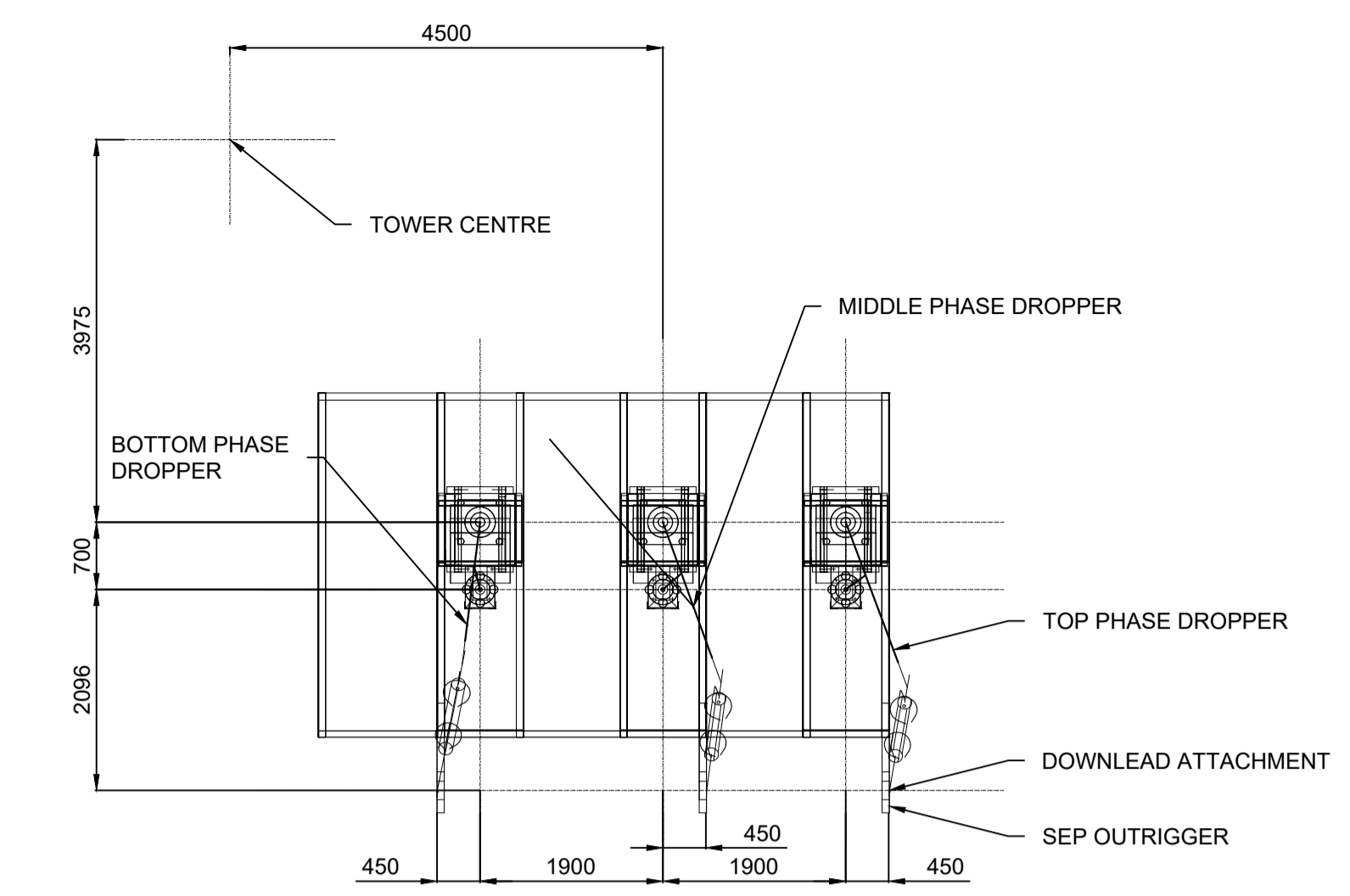

ENLARGED PLAN ON  
SEALING END PLATFORM  
1:100

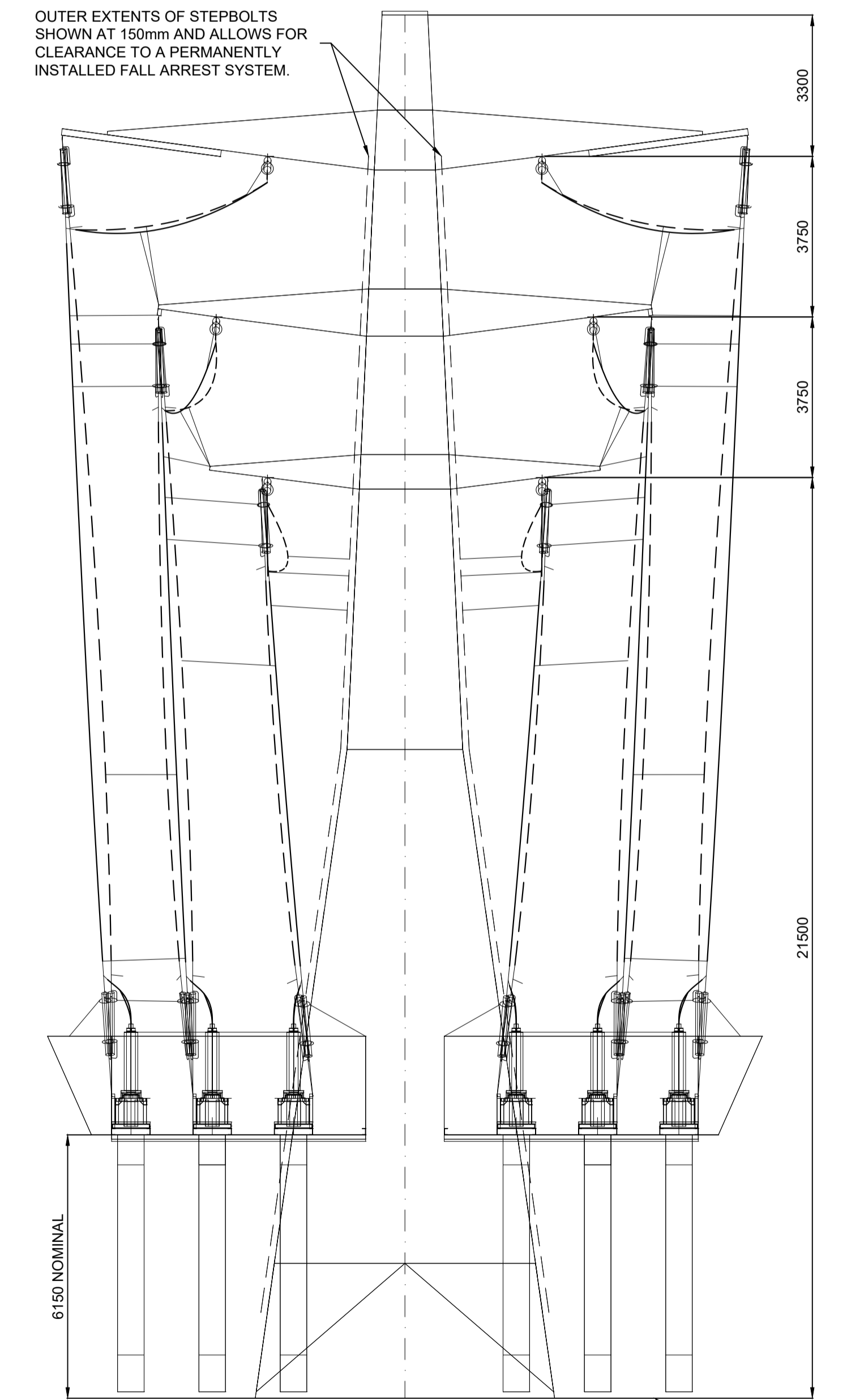

TRANSVERSE ELEVATION  
1:100

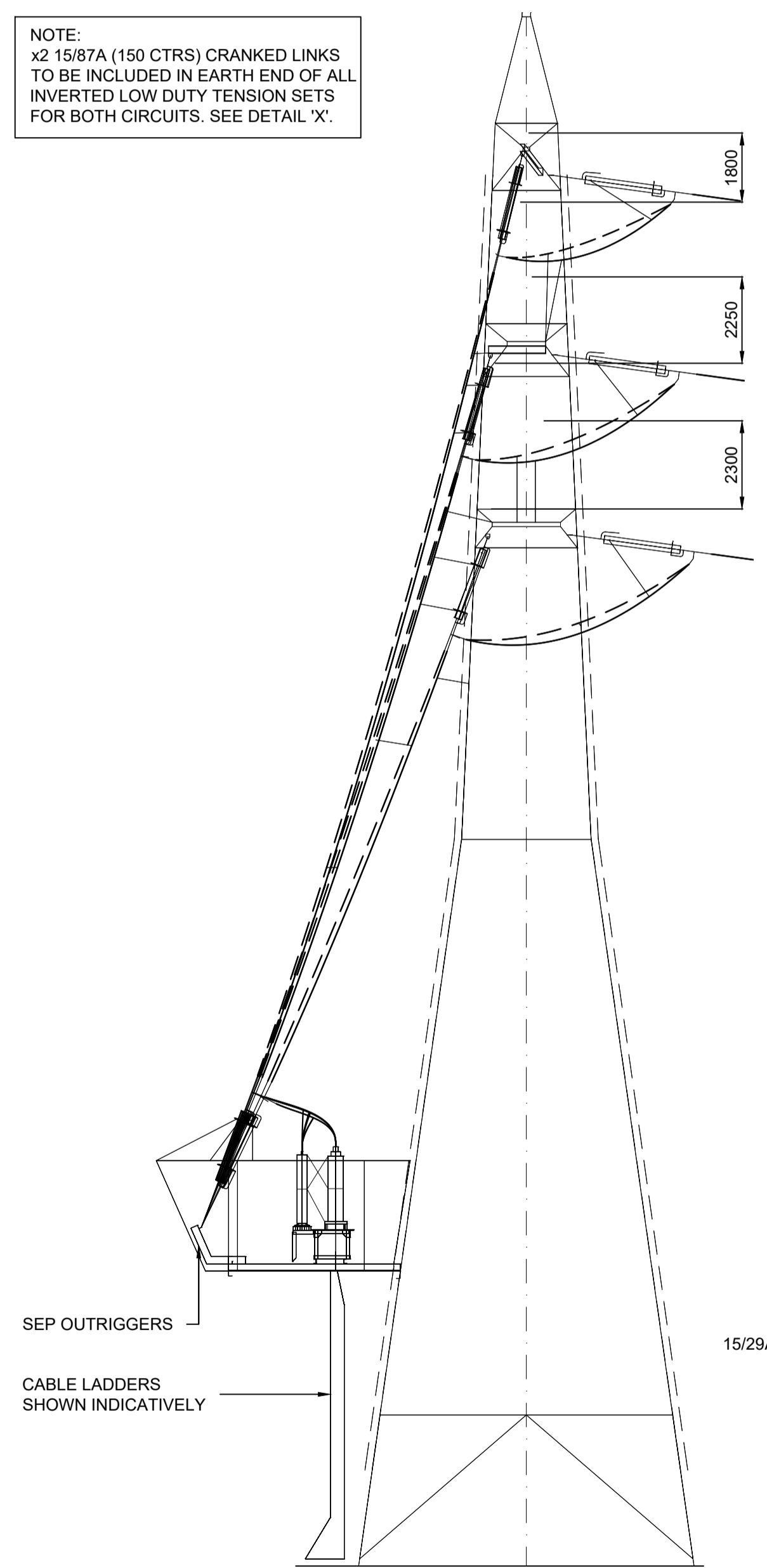

LONGITUDINAL ELEVATION  
1:100

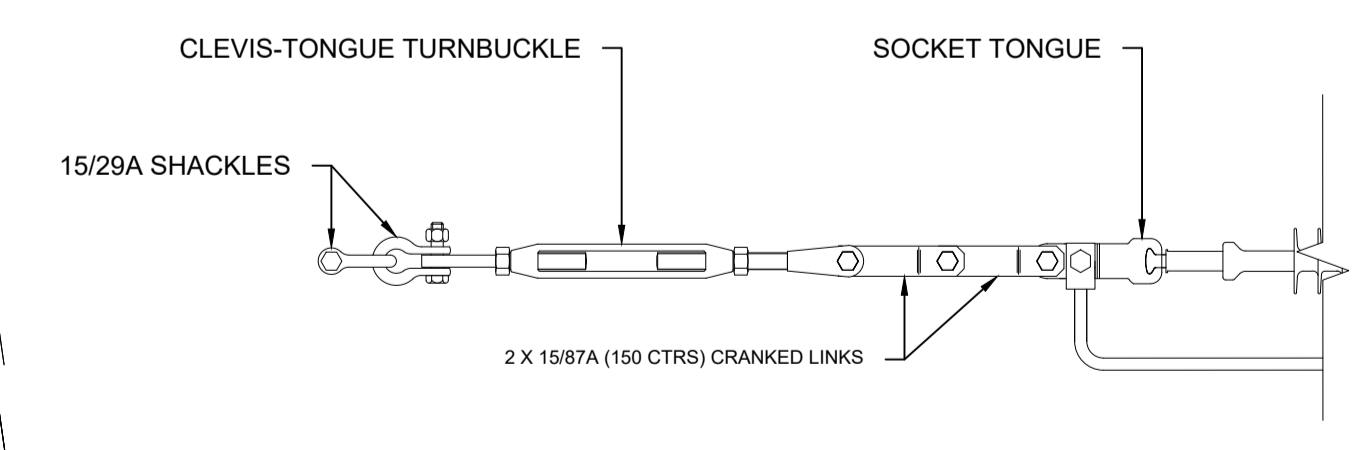

DETAIL X  
1:100

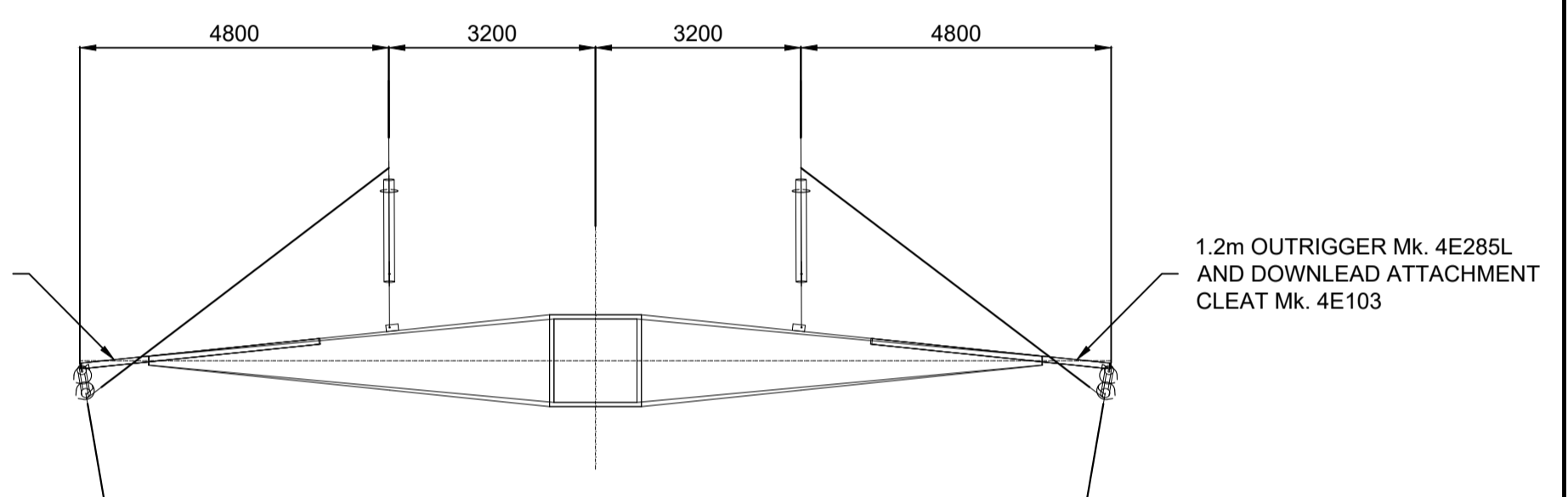

PLAN ON TOP CROSSARMS  
1:100

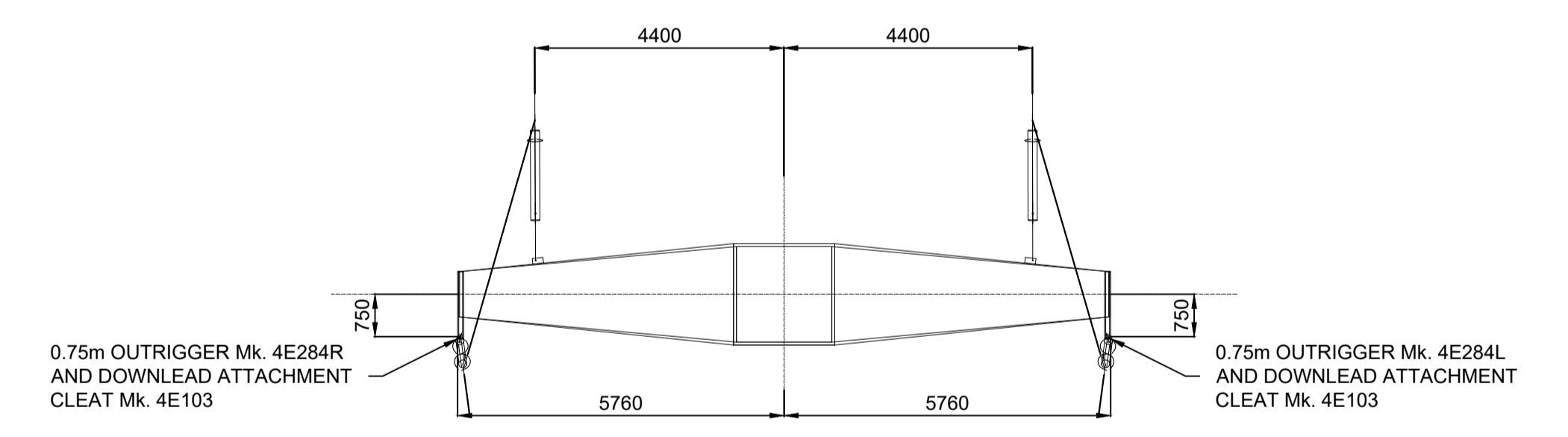

PLAN ON MIDDLE CROSSARMS  
1:100

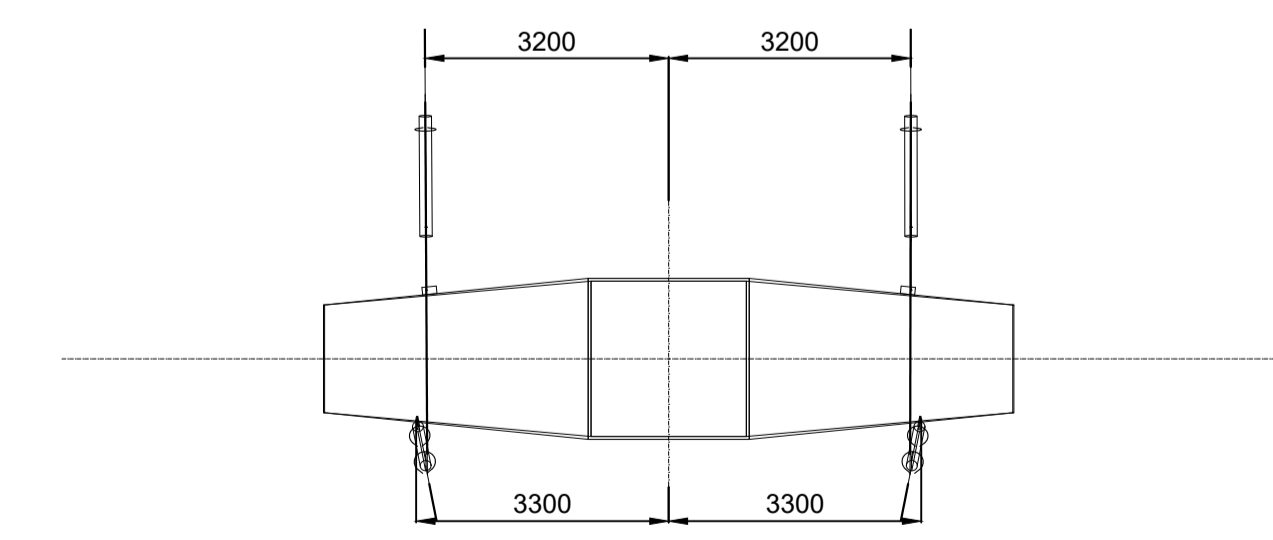

PLAN ON BOTTOM CROSSARMS  
1:100

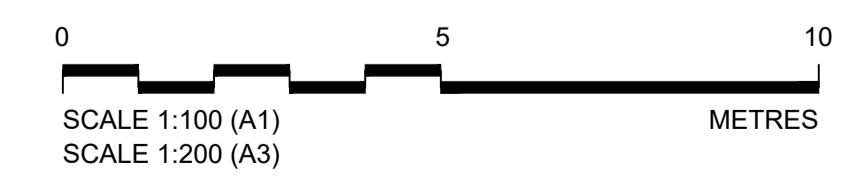

NOTES:  
1. The proposed design of the structure shown is illustrative only and will be subject to change as part of detailed design development. Any changes will be limited to being within the constraints included in the Development Consent Order (application document reference TR010032/APP/3.1).  
2. All dimensions are in millimetres unless stated otherwise.  
3. This is the assumed pylon type for pylon PEA16R however is subject to change at detailed design.

Rev	Status	Rev. Date	Purpose of revision	Drawn	Check'd	Apprv'd
P01.1	SO	02/08/2022	DCO Application	LY	EB	TW

	Client	Initial Status or WIP	Original Size	Revision
	Application Document Number	TR010032/APP/2.9	A1	P01.1
Project	LOWER THAMES CROSSING PYLON GENERAL ARRANGEMENT REGULATION 5(2)(o) AND 6(2) SHEET 1			
Drawing Number	HE540039-CJV-BOP-SZA_RX000000_-DR-CH-10807			



NOTE:  
TOWER, DOWNLOADS, JUMPERS AND STONEGUARD OMITTED FOR CLARITY.  
SEALING END PLATFORM, DOWNLOAD ATTACHMENT POSITIONS & DROPPER ARRANGEMENTS ARE SYMMETRICAL ABOUT TOWER CENTRE.

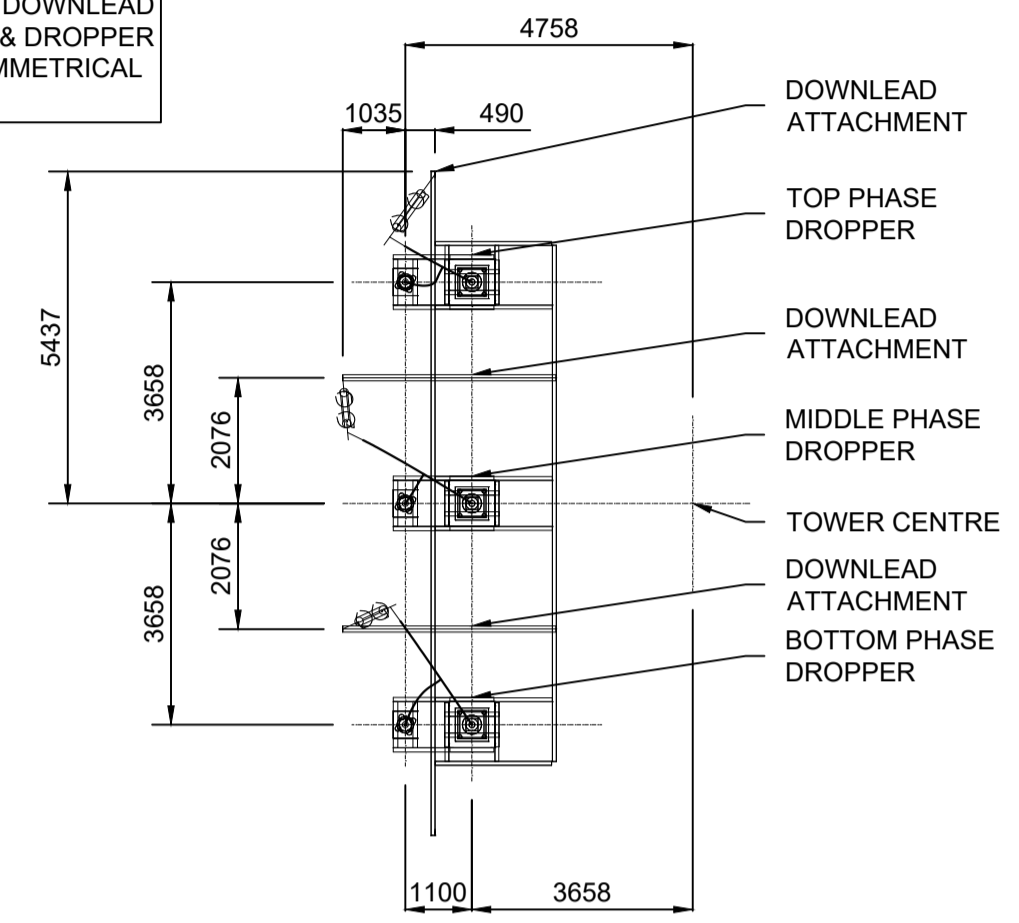

PLAN ON SEALING END PLATFORM  
1:100

CONDUCTOR PORTION OF THE BOTTOM PHASE DOWNLOAD EXPECTED TO BE LESS THAN 300mm IN LENGTH. UNDER THERE IS A RISK THAT THE CONDUCTOR COULD BE SUSCEPTIBLE TO BIRD CAGING DURING CRIMPING ON THE TENSION CLAMPS EITHER END. A MORE PRACTICAL ARRANGEMENT WOULD BE TO RUN THE BOTTOM JUMPER LOOP DIRECTLY DOWN TO THE SE & AND STACKS. SEE DETAIL 'X'.

ADDITIONAL CRANKED LINKS REQUIRED IN EARTH-END OF TOP AND BOTTOM PHASE INVERTED LOW DUTY TENSION SETS. SEE DETAIL 'Y' FOR PLACEMENT AND QUANTITIES.

DETAILS OF NEW CABLE LADDERS NOT SHOWN

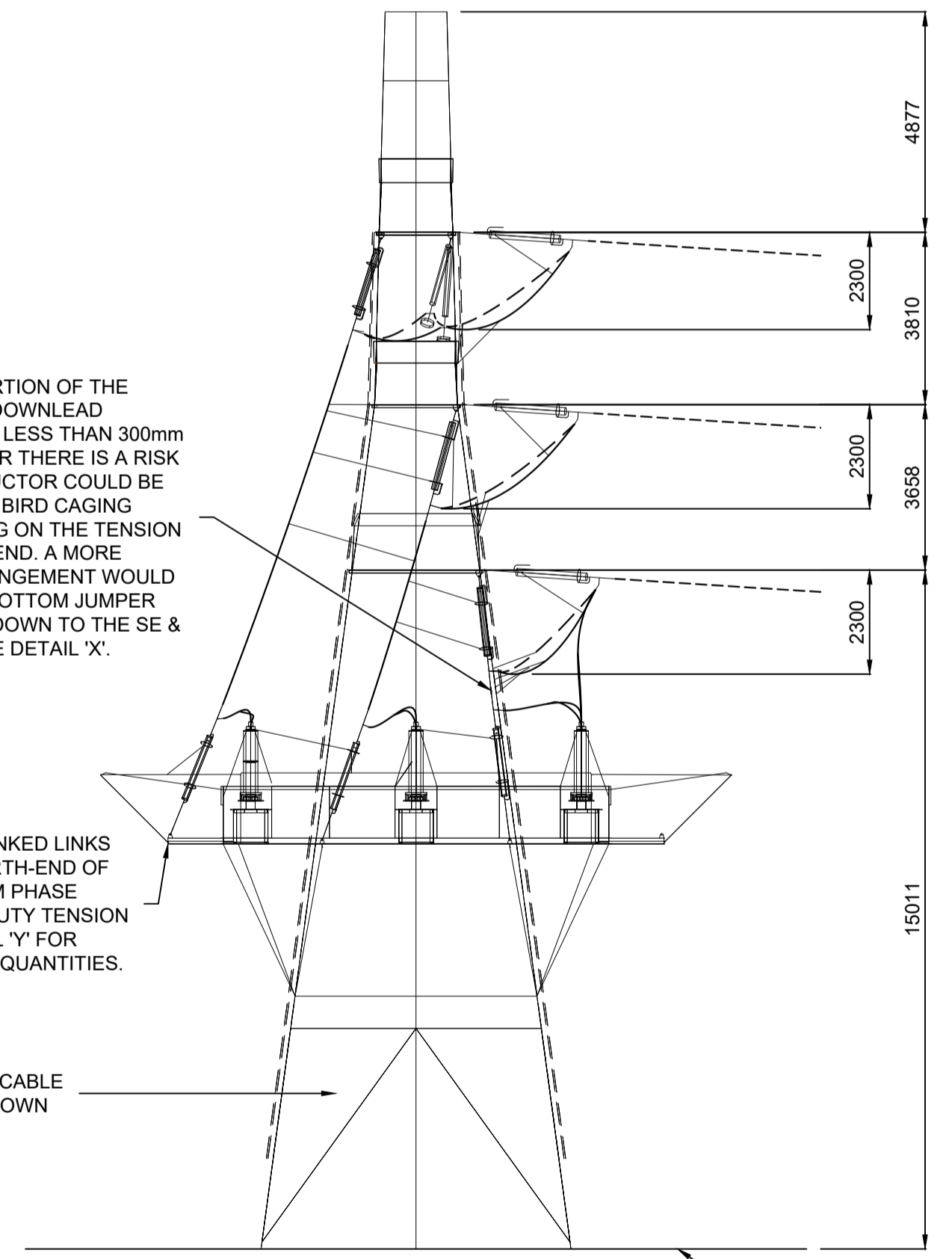

LONGITUDINAL ELEVATION SHOWING TILBURY SHELL CIRCUIT 1 ONLY  
1:100

NOTE:  
ALL NEW DOWNLOAD AND PILOT SET VERTICAL ATTACHMENT PLATES TO BE FITTED TO THE LONGITUDINAL FACE OF EACH CROSSARM END (AS PER SECTION A-A OF BK35/23261 [XM2092-44]).

PLATES SHOULD BE INSTALLED WITH THE BEND TOWARDS THE TOWER BODY ON THE TOP CROSSARM AND AWAY FROM THE TOWER BODY ON THE MIDDLE AND BOTTOM CROSSARMS.

NEW DOWNLOAD ATTACHMENT PLATE Mk.LA (C/W 2x S355JR M16x50lg HEX HD BOLTS, EACH WITH 1x NUT, 1x PALNUT & 1x4mm THK FLAT WASHER)

NEW PILOT SET ATTACHMENT PLATE Mk.LA (C/W 2x S355JR M16x50lg HEX HD BOLTS, EACH WITH 1x NUT, 1x PALNUT & 1x4mm THK FLAT WASHER)

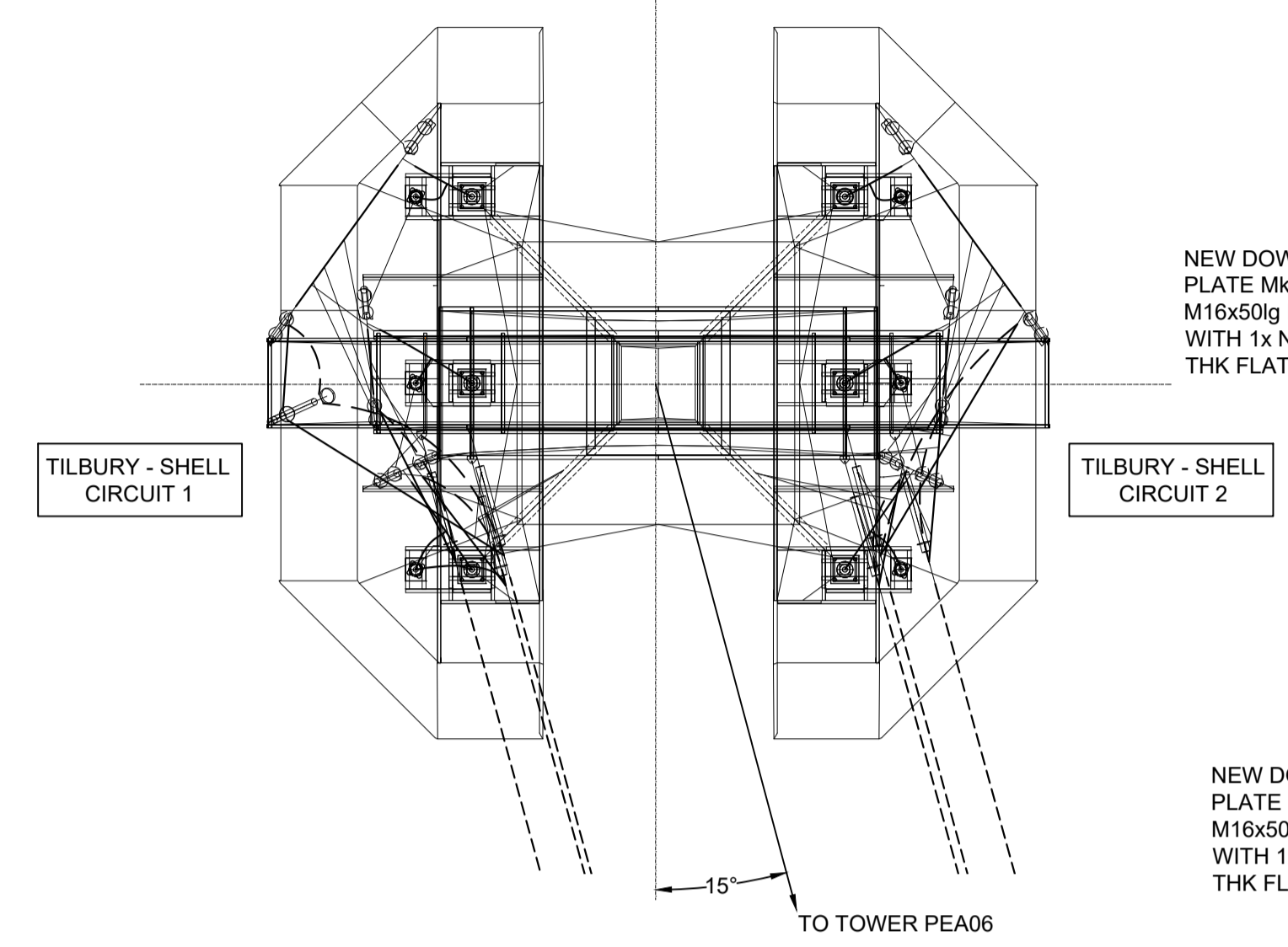

PLAN  
1:8

NEW DOWNLOAD ATTACHMENT PLATE Mk.LA (C/W 2x S355JR M16x50lg HEX HD BOLTS, EACH WITH 1x NUT, 1x PALNUT & 1x4mm THK FLAT WASHER)

NEW DOWNLOAD ATTACHMENT PLATE Mk.LA (C/W 2x S355JR M16x50lg HEX HD BOLTS, EACH WITH 1x NUT, 1x PALNUT & 1x4mm THK FLAT WASHER)

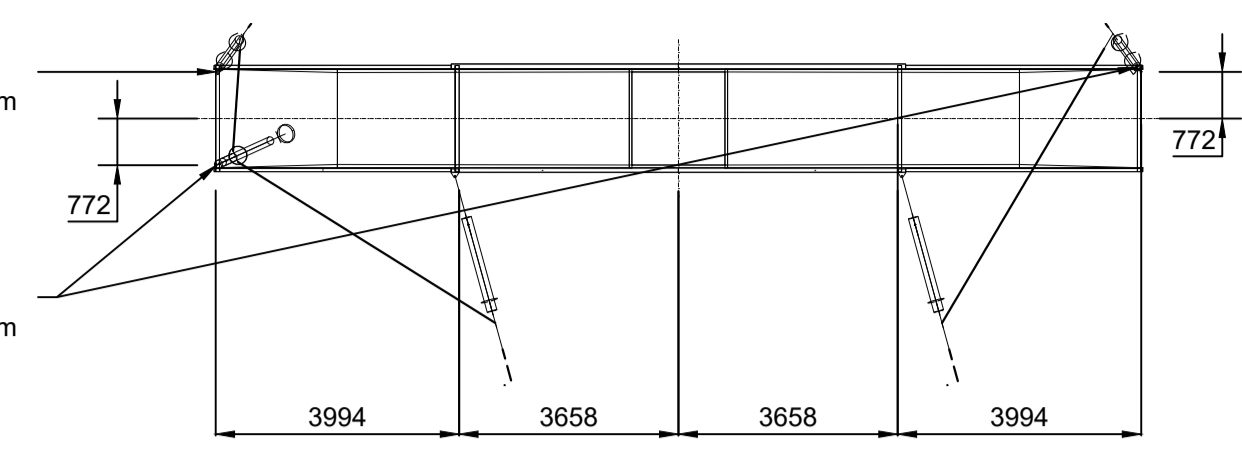

PLAN ON TOP CROSSARMS  
1:100

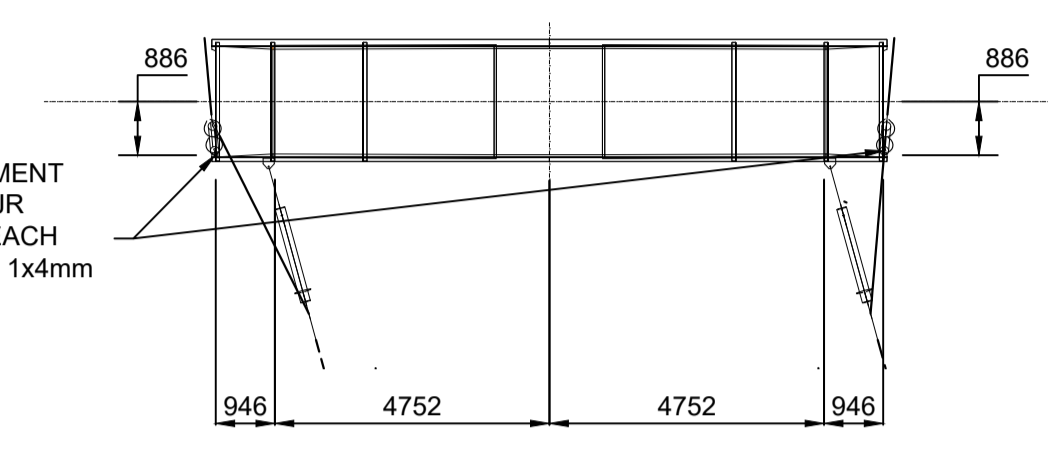

PLAN ON MIDDLE CROSSARMS  
1:100

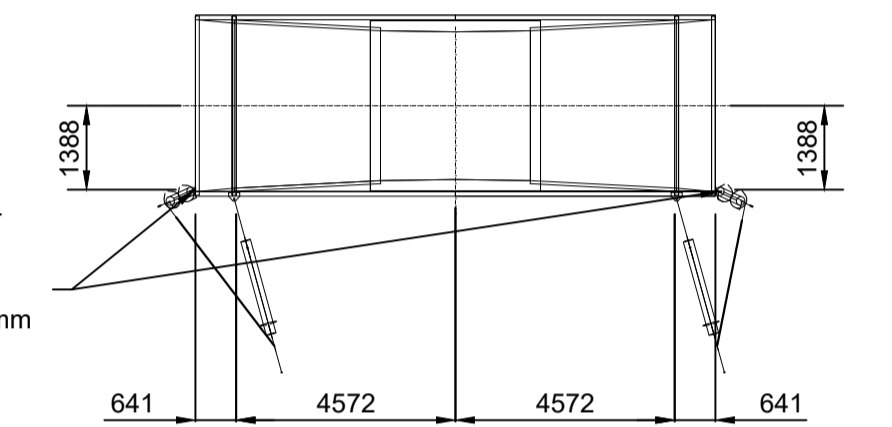

PLAN ON BOTTOM CROSSARMS  
1:100

CONDUCTOR PORTION OF THE BOTTOM PHASE DOWNLOAD EXPECTED TO BE LESS THAN 300mm IN LENGTH. UNDER THERE IS A RISK THAT THE CONDUCTOR COULD BE SUSCEPTIBLE TO BIRD CAGING DURING CRIMPING ON THE TENSION CLAMPS EITHER END. A MORE PRACTICAL ARRANGEMENT WOULD BE TO RUN THE BOTTOM JUMPER LOOP DIRECTLY DOWN TO THE SE & AND STACKS. SEE DETAIL 'X'.

LIVE END ARCING HORN TO SEP HANDRAIL

LIVE END ARCING HORN TO SEP HANDRAIL

LINES REPRESENT OUTER EXTENT OF STEPBOLTS SHOWN AT 150mm AND ALLOWS FOR CLEARANCE TO A PERMANENTLY INSTALLED FALL ARREST SYSTEM

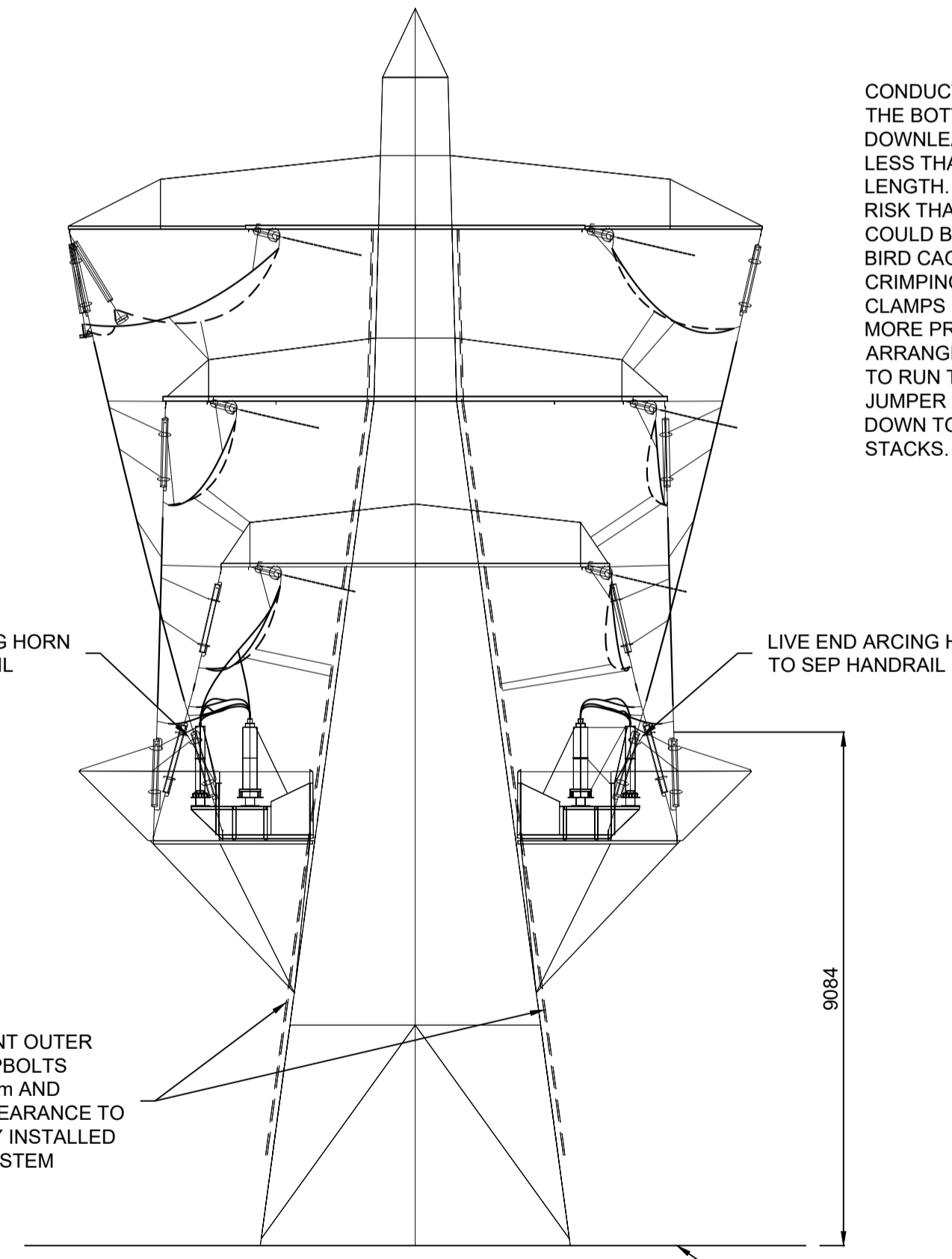

TRANSVERSE ELEVATION  
1:100

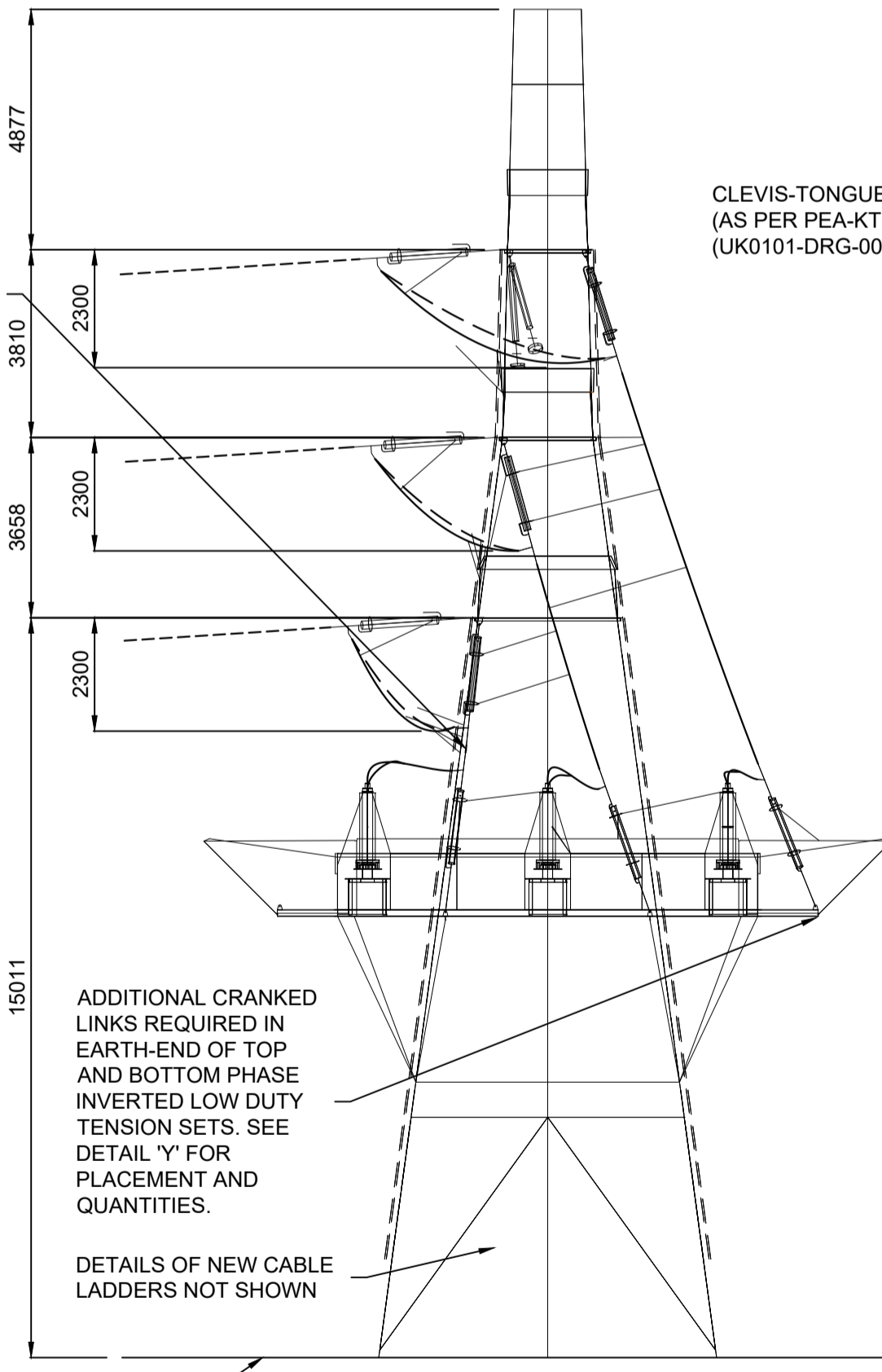

LONGITUDINAL ELEVATION SHOWING TILBURY SHELL CIRCUIT 2 ONLY  
1:100

NOTE:  
FOR BOTTOM PHASE ONLY. THE JUMPER, DOWNLOAD, UPRIGHT AND INVERTED LOW DUTY SETS ARE REPLACED WITH AN ALTERNATIVE ARRANGEMENT THAT CONNECTS THE MAINLINE INSULATORS DIRECTLY TO THE SURGE ARRESTER/SEALING END.

ALTERNATIVE DROPPER ARRANGEMENT REMOVES THE NEED FOR A BOTTOM PHASE DOWNLOAD, JUMPER, UPRIGHT AND INVERTED LOW-DUTY INSULATOR SETS.

CLEARANCES HAVE BEEN VERIFIED FOR THE ALTERNATIVE ARRANGEMENT.

UPAS TEE CONNECTOR (SEE MOSDORFER DRG-226314-NGC)  
UPAS STRAIGHT JUMPER PALM SEE MOSDORFER DRG-226337-NGC)  
SEALING END STEM TERMINATION CONNECTOR (SEE DRG-9049/25/50A)

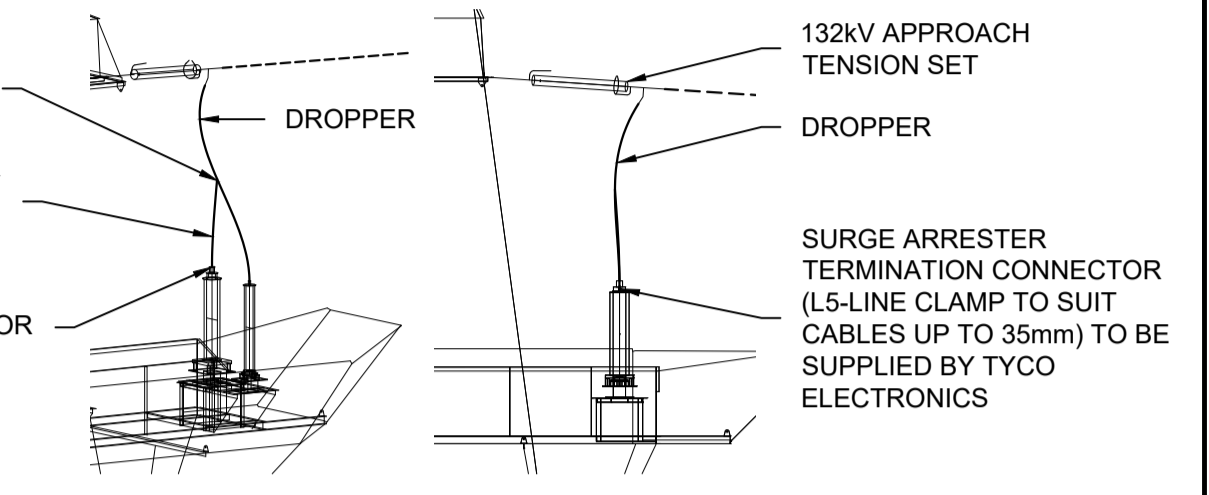

DETAIL X  
ALTERNATIVE BOTTOM PHASE DROPPER ARRANGEMENT SHOWING CIRCUIT 1 ONLY  
1:100

NOTE:  
ADDITIONAL FITTINGS REQUIRED IN EARTH-END OF INVERTED LOW DUTY TENSION SETS

CLEVIS-TONGUE TURNBUCKLE (AS PER PEA-KTB-DR-106775-37-4102 (UK0101-DRG-003))

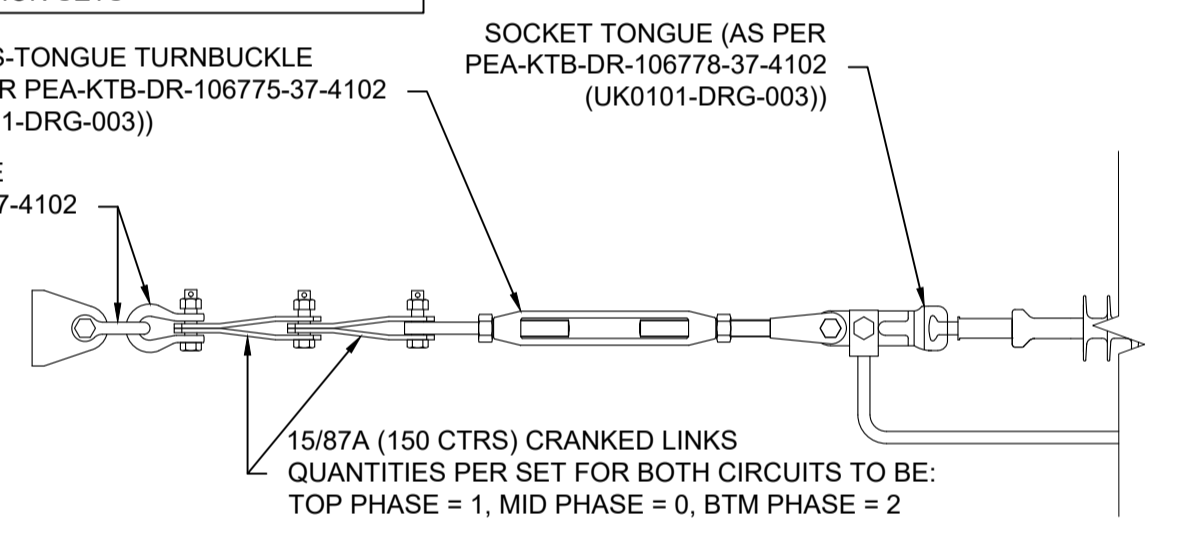

DETAIL Y  
1:100

UPAS TEE CONNECTOR (SEE MOSDORFER DRG-226314-NGC)  
UPAS STRAIGHT JUMPER PALM (SEE MOSDORFER DRG-226337-NGC)  
TOWER LEG  
HANDRAIL  
200mm HIGH UPSTAND TO BE DETAILED TO CONNECT TO MEMBER PL16-ST-5

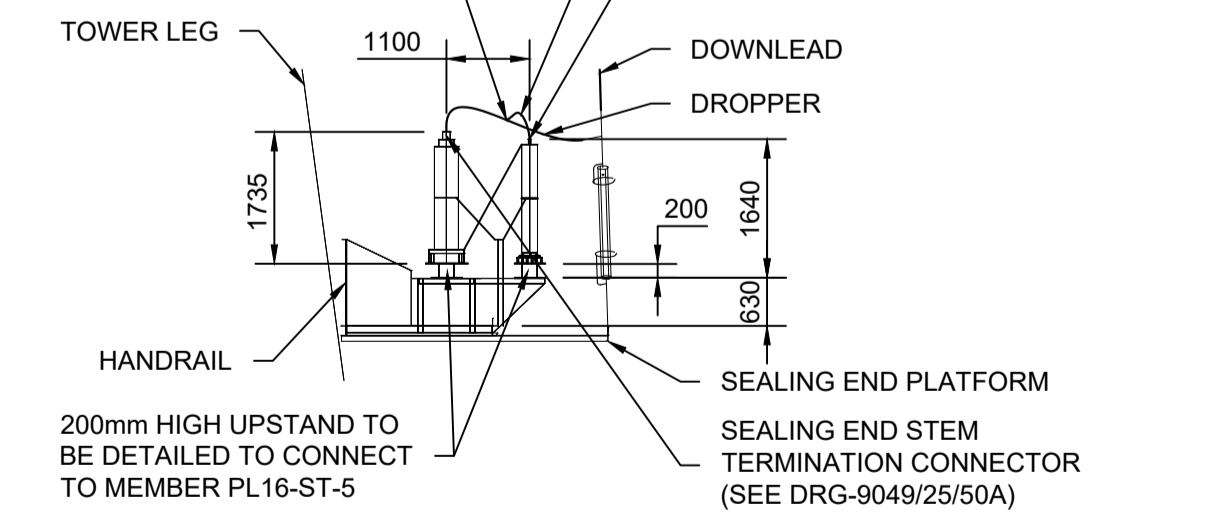

DETAIL Z  
TYPICAL ENLARGED VIEW OF SEALING END AND SURGE ARRESTERS  
1:100

NOTES:  
1. The proposed design of the structure shown is illustrative only and will be subject to change as part of detailed design development. Any changes will be limited to being within the constraints included in the Development Consent Order (application document reference TR010032/APP/3.1).  
2. All dimensions are in millimetres unless stated otherwise.  
3. This is the assumed pylon type for pylon PEA07 however is subject to change at detailed design.

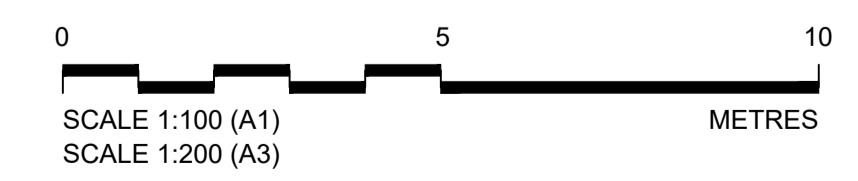

LOWER THAMES CROSSING

Status	Initial Status or WIP	Original Size	A1	Revision	P01.1
Application Document Number	TR010032/APP/2.9	Scale	AS SHOWN		
Drawing title	PYLON GENERAL ARRANGEMENT REGULATION 5(2)(o) AND 6(2) SHEET 2				
Drawing Number	HE540039-CJV-BOP-SZA_RX000000_-DR-CH-10808				

P01.1	SO	02/08/2022	DCO Application	LY	EB	TW
Rev	Status	Rev. Date	Purpose of revision	Drawn	Chk'd	Apprv'd

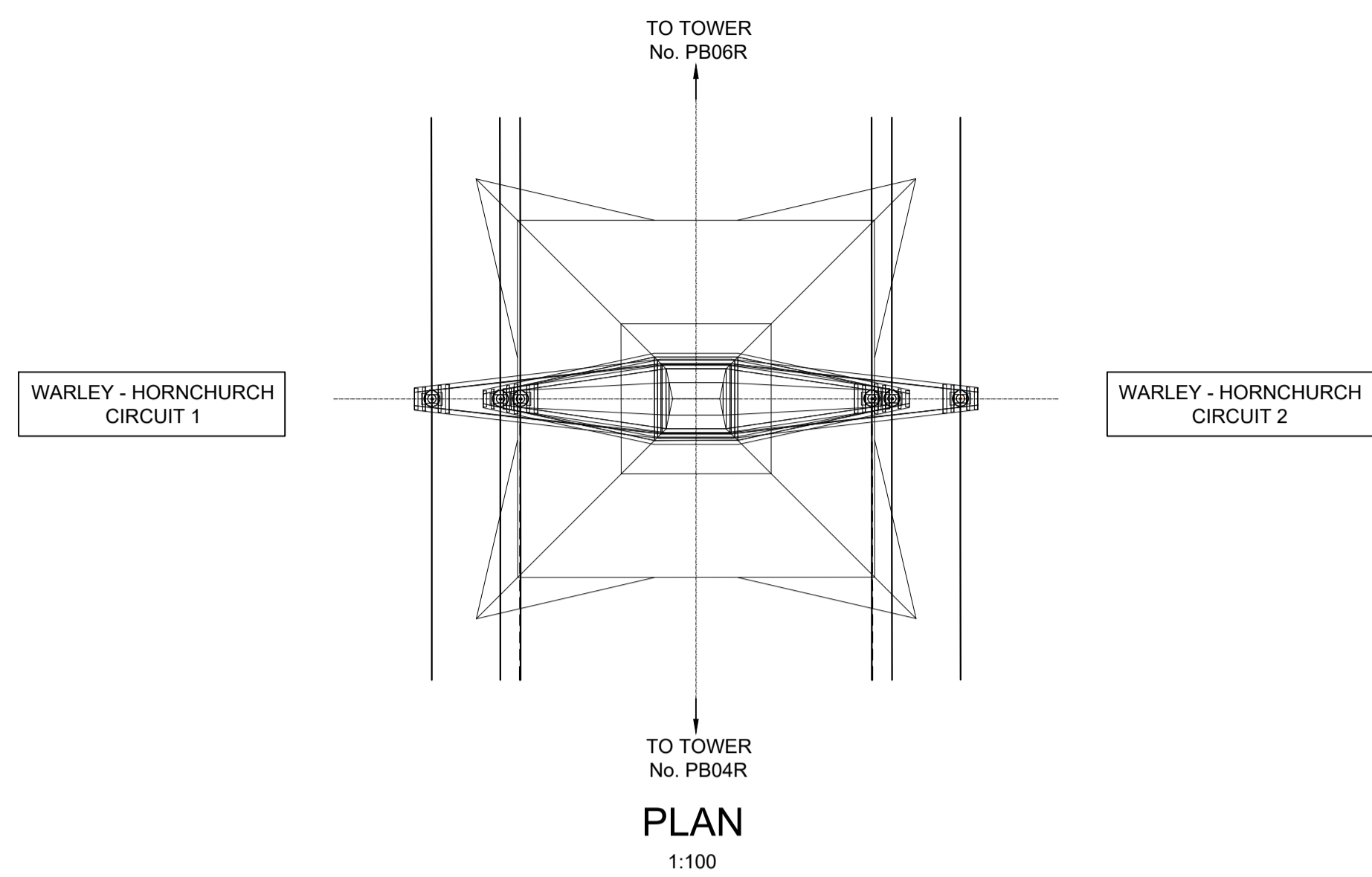

NOTE:  
 x1 28/87 CRANKED LINK TO BE USED ON TOP PHASES ONLY, AS PER DRAWING PB-KTB-DR-106778-37-4001 (UK0103-DRG-002)

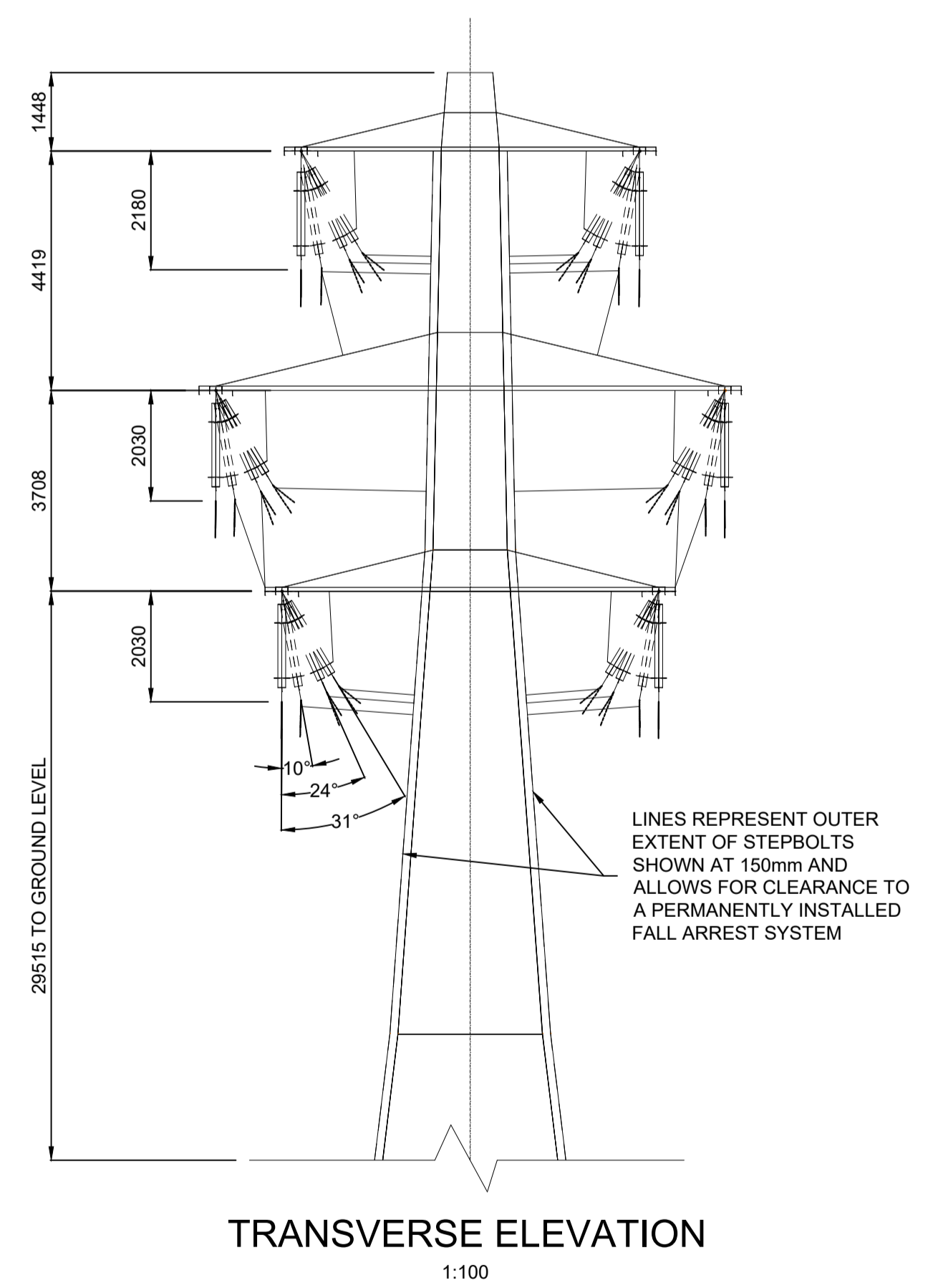
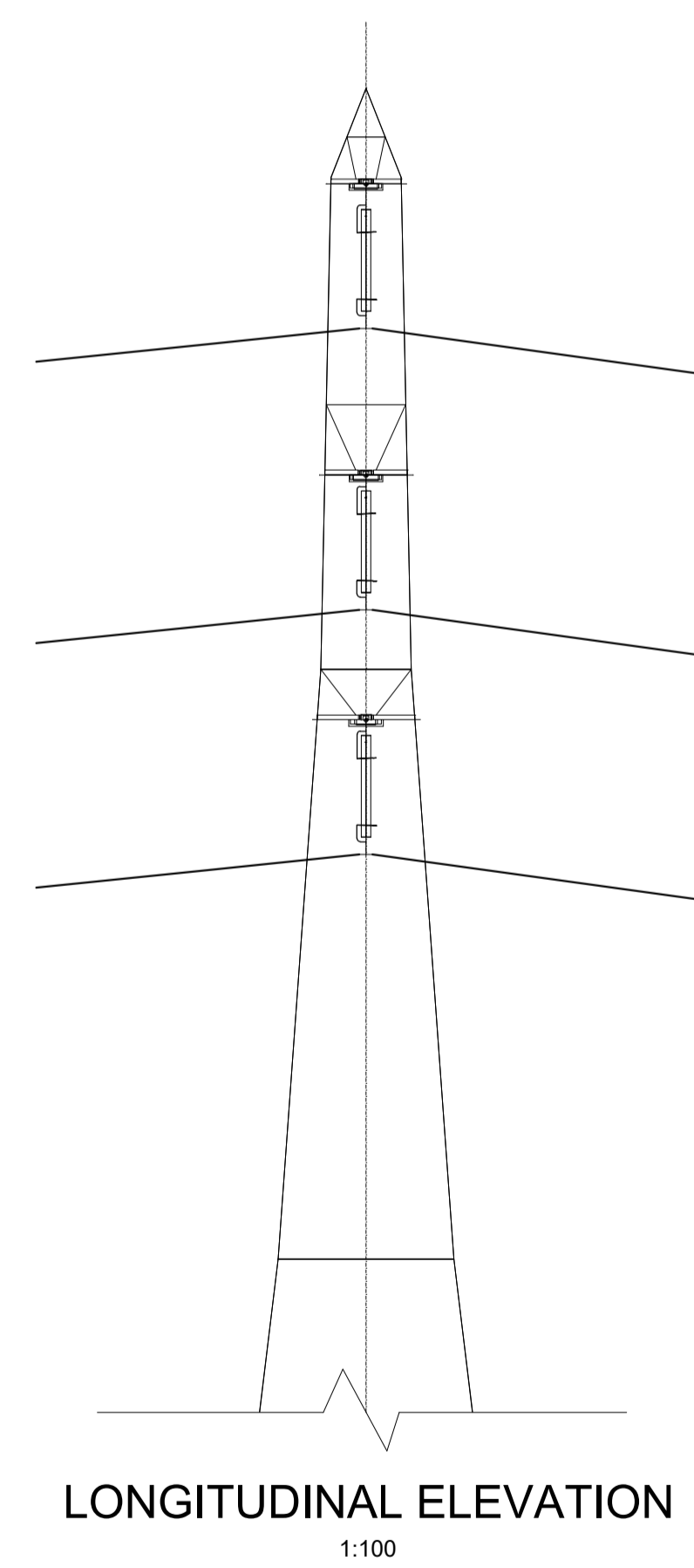
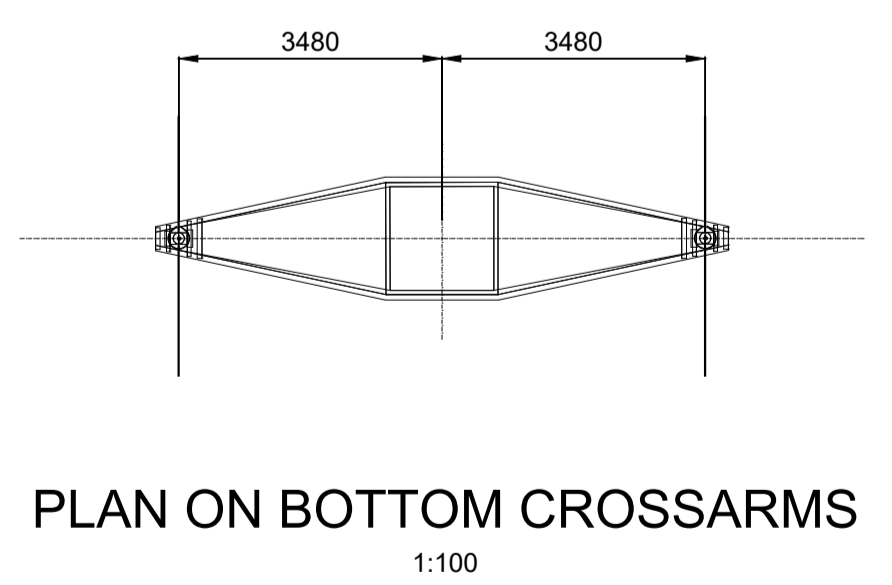
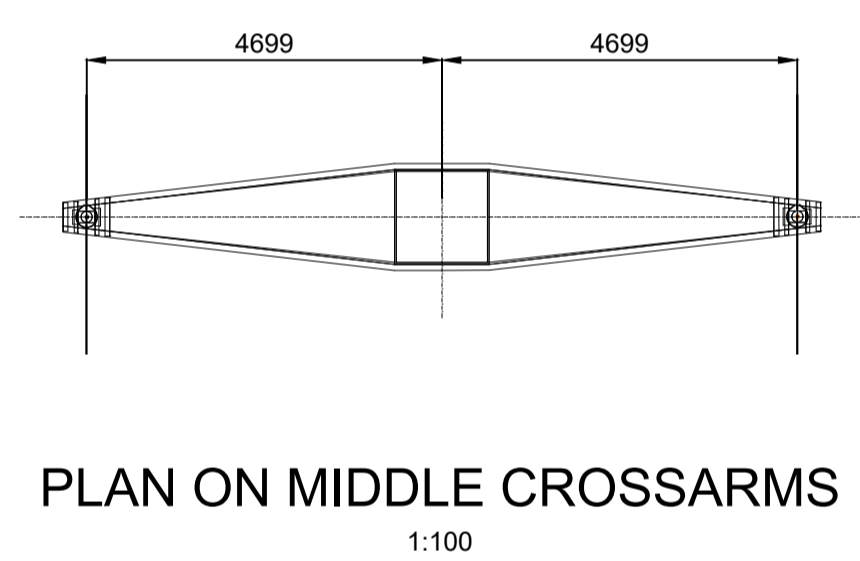
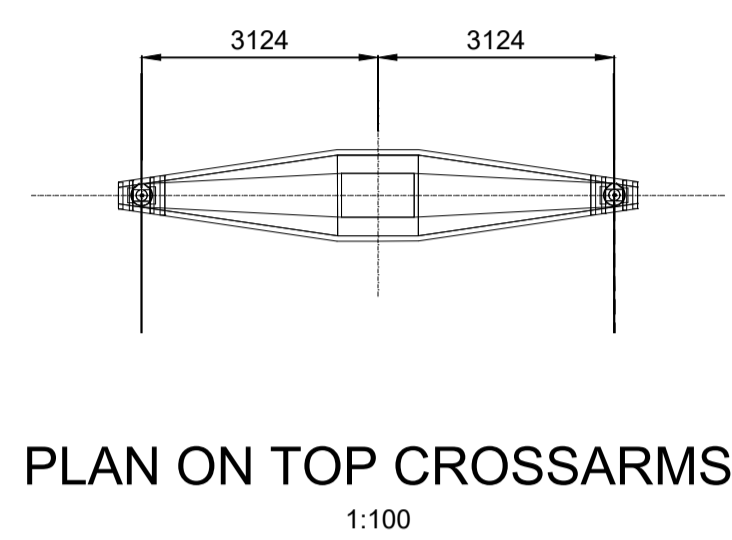

NOTES:  
 1. The proposed design of the structure shown is illustrative only and will be subject to change as part of detailed design development. Any changes will be limited to being within the constraints included in the Development Consent Order (application document reference TR010032/APP/3.1).  
 2. All dimensions are in millimetres unless stated otherwise.  
 3. This is the assumed pylon type for pylon PB05R however is subject to change at detailed design.

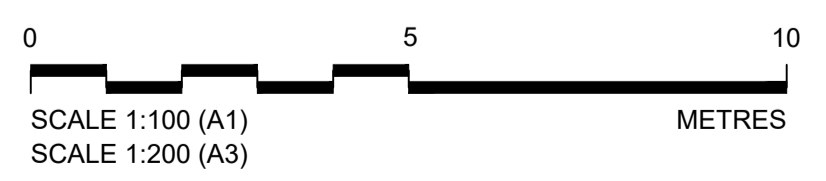

LOWER THAMES CROSSING

Status	Initial Status or WIP	Original Size	A1	Revision	P01.1
Application Document Number	TR010032/APP/2.9	Scale	AS SHOWN		
Drawing title	PYLON GENERAL ARRANGEMENT REGULATION 5(2)(o) AND 6(2) SHEET 3 - L7c D E12				
Drawing Number	HE540039-CJV-BOP-SZA_RX000000_-DR-CH-10809				

Contains Ordnance Survey data. © Crown copyright and database rights 2022. Ordnance Survey 100030649						
Rev	Status	Rev. Date	Purpose of revision	Drawn	Check'd	Apprv'd
P01.1	SO	06/09/2022	DCO APPLICATION	LY	EB	TW

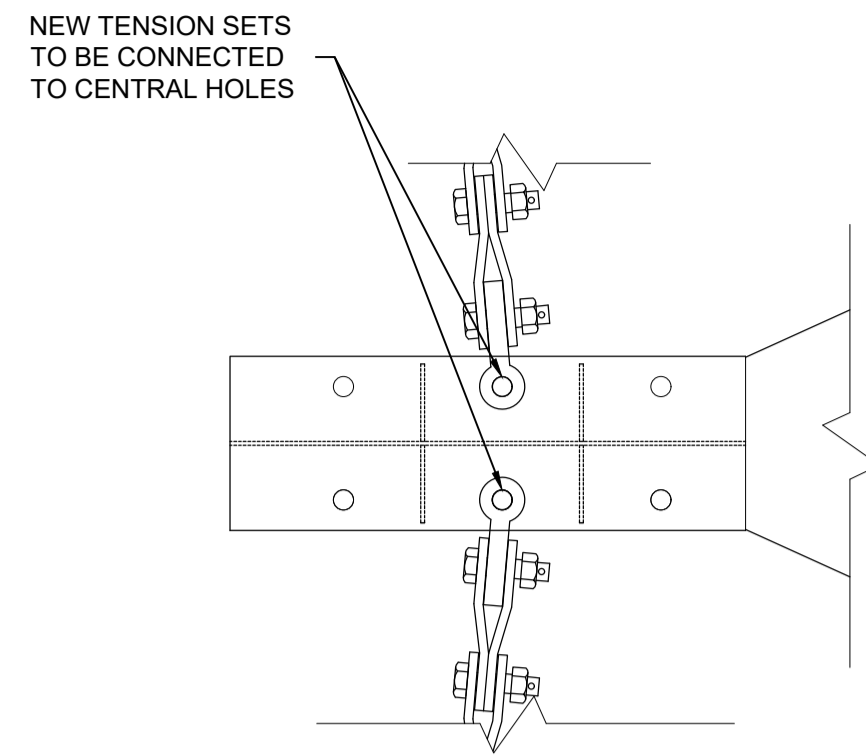

**DETAIL A**  
TYPICAL TENSION SET ATTACHMENT  
NOT TO SCALE

NOTE:  
NON-TENSION JOINTS TO BE INSTALLED WHERE  
CLAMPS ARE USED AND CONDUCTOR TAILS NEED  
TO BE CONNECTED TO FORM JUMPER LOOPS

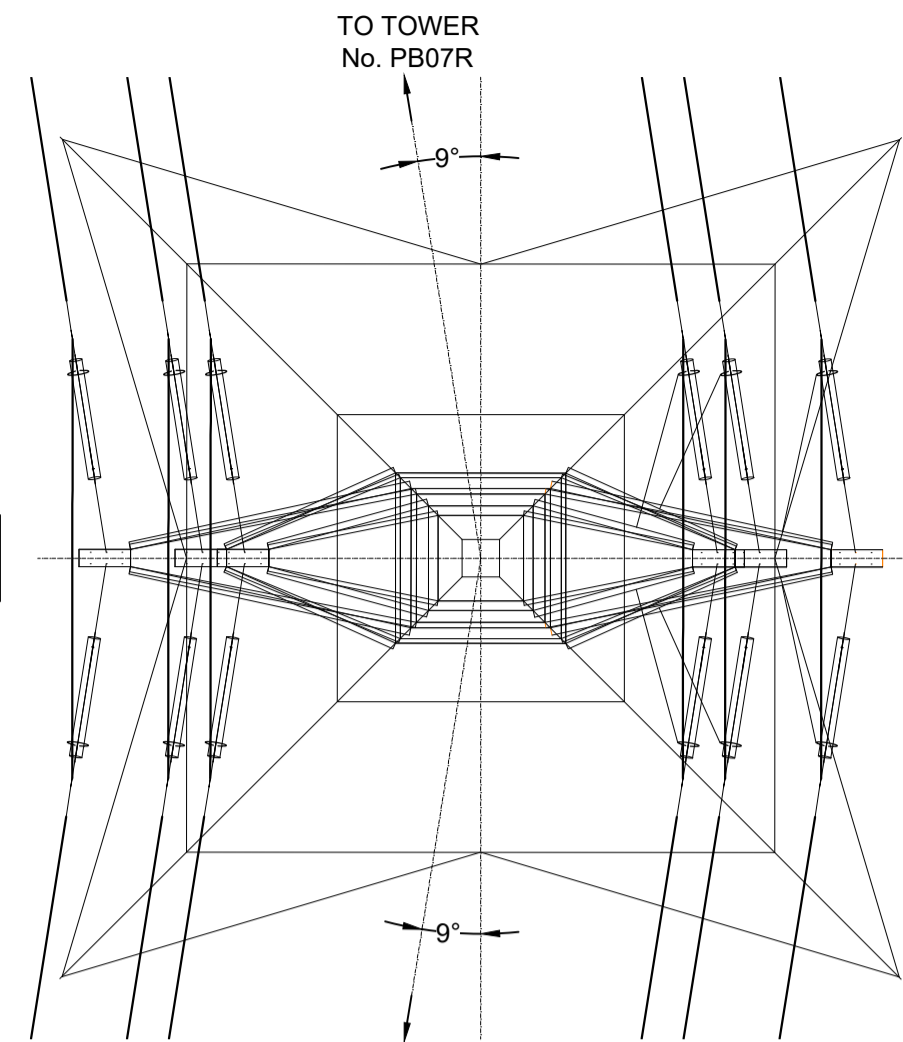

**PLAN**  
1:100

NOTE:  
ALL SETS CONNECTED TO CENTRAL SWIVEL  
ATTACHMENT POSITION WITHIN WELDED  
CROSSARM END ASSEMBLY - SEE DETAIL A

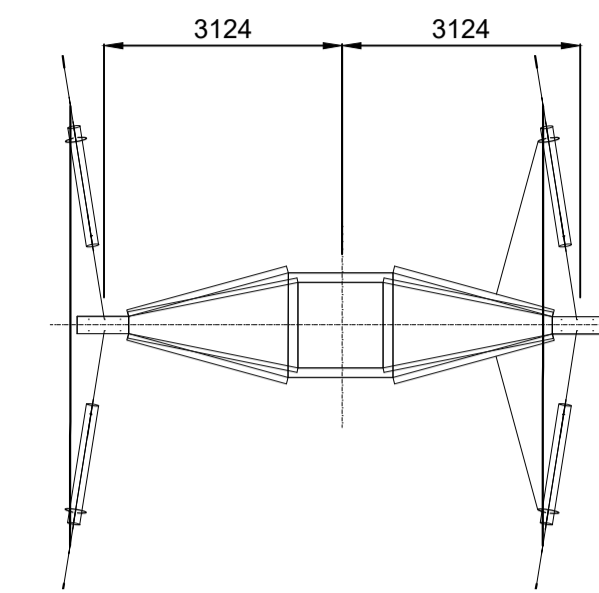

**PLAN ON TOP CROSSARMS**  
1:100

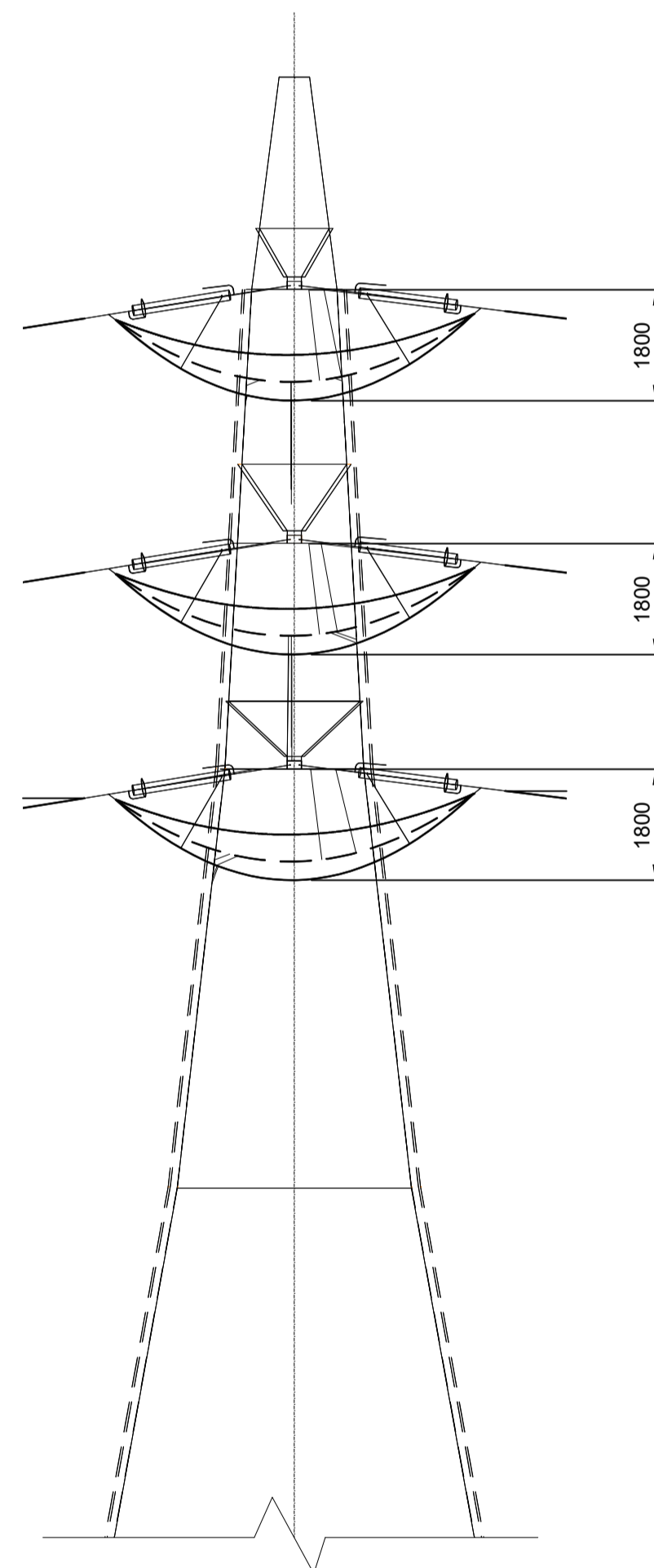

**LONGITUDINAL ELEVATION**  
SHOWING WARLEY - HORNCHURCH CIRCUIT 1 ONLY  
1:100

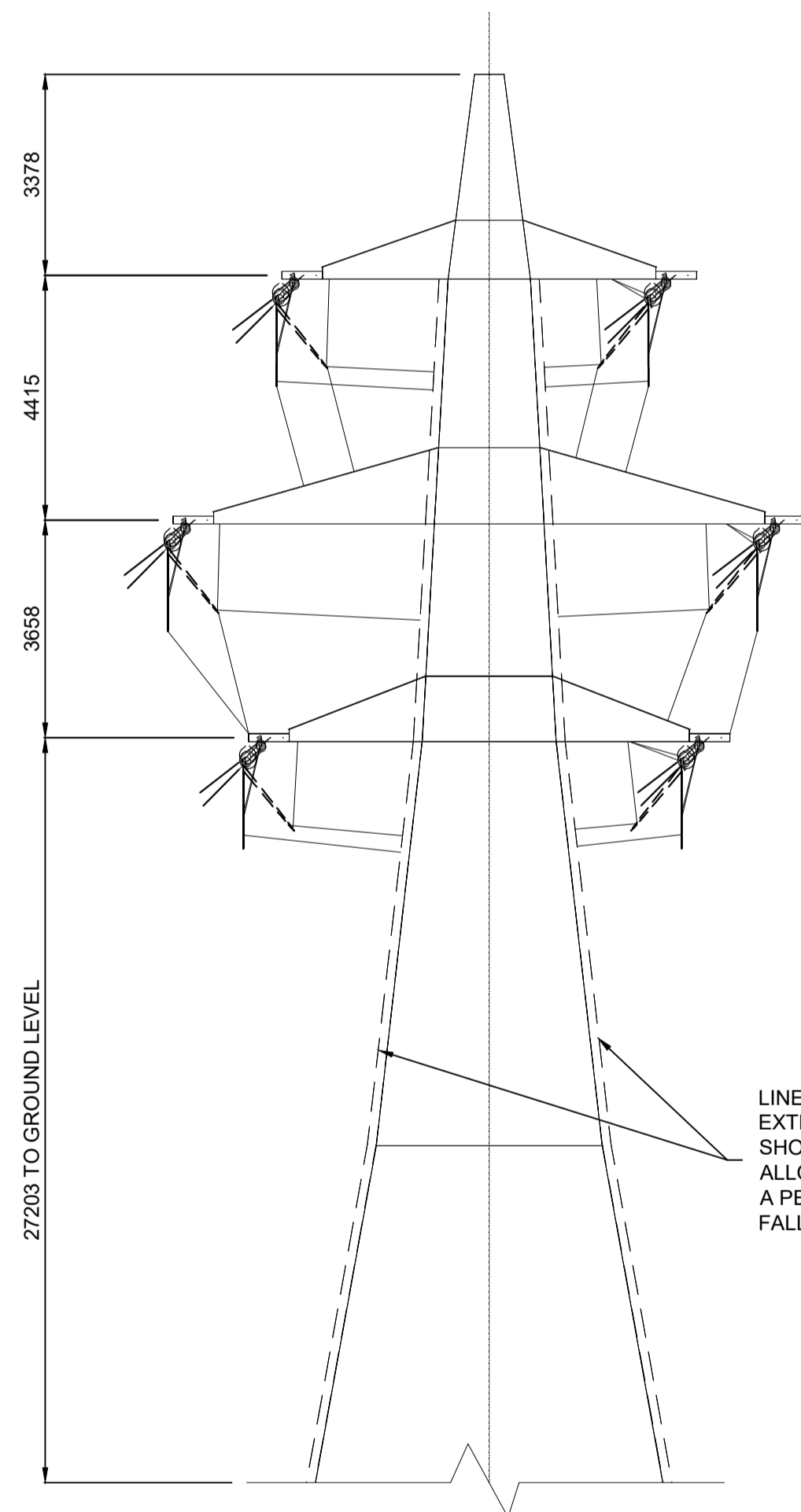

**TRANSVERSE ELEVATION**  
1:100

LINES REPRESENT OUTER  
EXTENT OF STEPBOLTS  
SHOWN AT 150mm AND  
ALLOWS FOR CLEARANCE TO  
A PERMANENTLY INSTALLED  
FALL ARREST SYSTEM

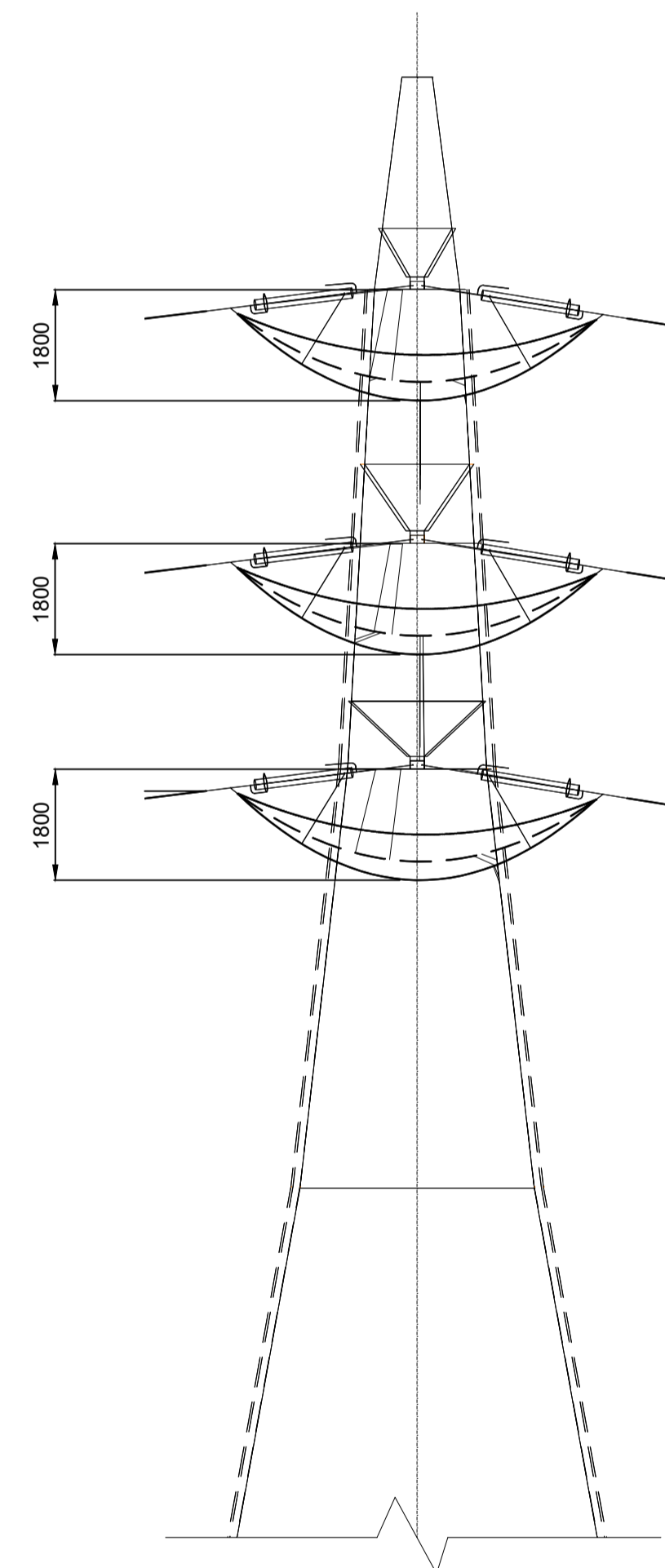

**LONGITUDINAL ELEVATION**  
SHOWING WARLEY - HORNCHURCH CIRCUIT 2 ONLY  
1:100

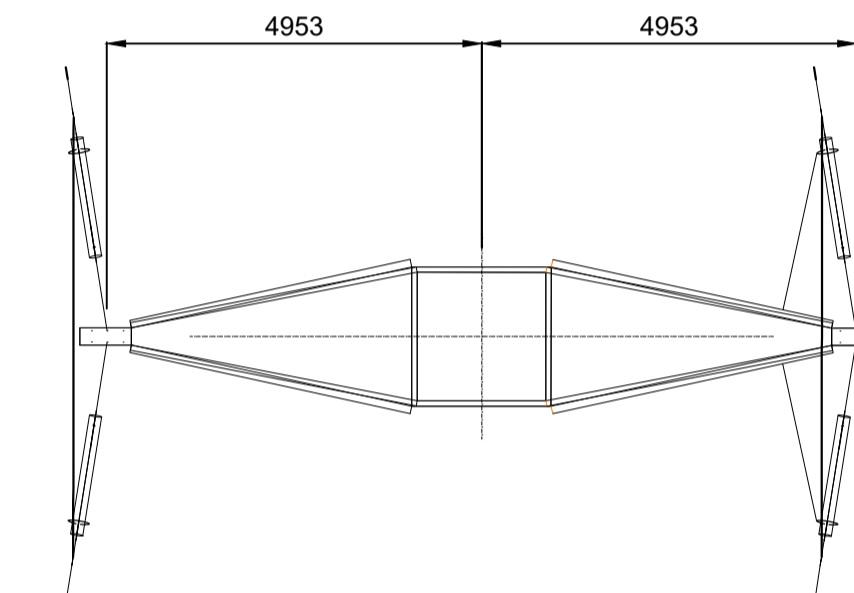

**PLAN ON MIDDLE CROSSARMS**  
1:100

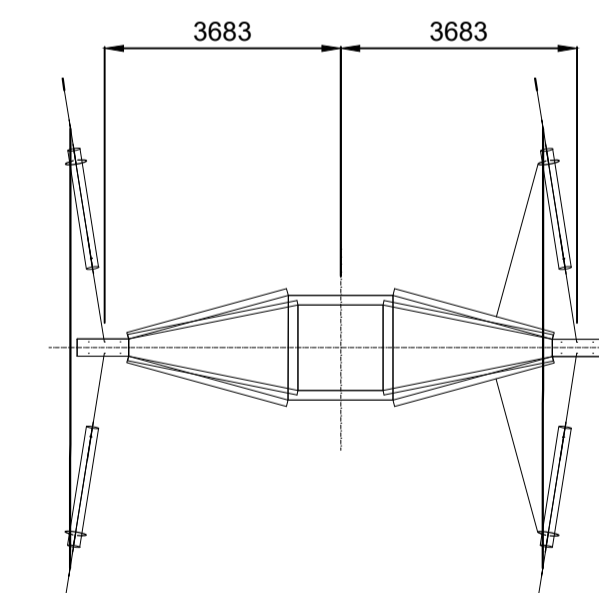

**PLAN ON BOTTOM CROSSARMS**  
1:100

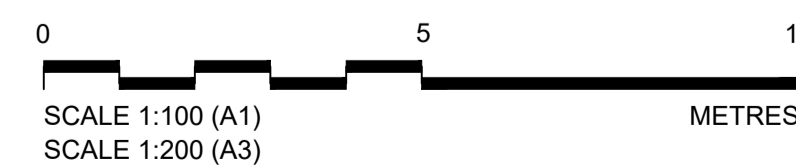

Contains Ordnance Survey data. © Crown copyright and database rights 2022. Ordnance Survey 100030649

**NOTES:**

1. The proposed design of the structure shown is illustrative only and will be subject to change as part of detailed design development. Any changes will be limited to being within the constraints included in the Development Consent Order (application document reference TR010032/APP/3.1).
2. All dimensions are in millimetres unless stated otherwise.
3. This is the assumed pylon type for Pylons PB06R however is subject to change at detailed design.

Rev	Status	Rev. Date	Purpose of revision	Drawn	Check'd	Apprv'd
P01.1	SO	06/09/2022	DCO APPLICATION	LY	EW	TB

Client



LOWER THAMES CROSSING

Status	Initial Status or WIP	Original Size	Revision
Application Document Number	TR010032/APP/2.9	A1	P01.1
Drawing title		Scale AS SHOWN	

**PYLON GENERAL ARRANGEMENT**  
REGULATION 5(2)(o) AND 6(2)  
SHEET 4 - L7c D30 E12

Drawing Number  
HE540039-CJV-BOP-SZA\_RX000000\_-DR-CH-10810

NOTE:  
0° DEVIATION:  
SHOWING POSITIONS OF  
MINIMUM CLEARANCE AT  
BOTTOM CROSSARM LEVEL

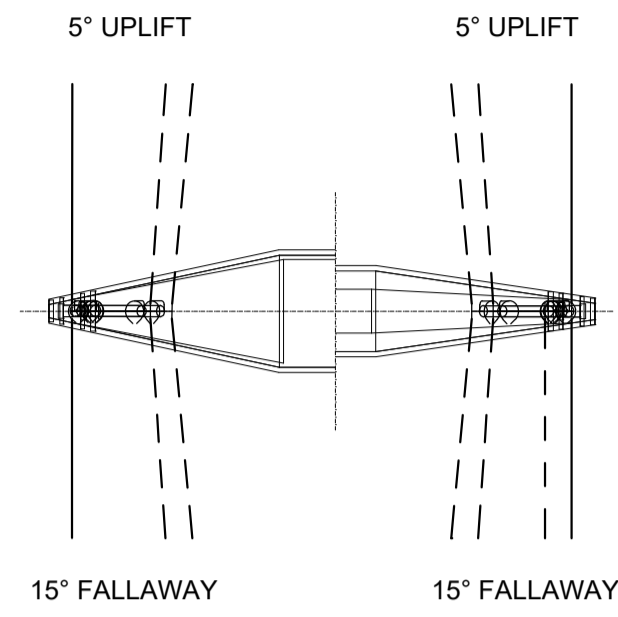

NOTE:  
0° DEVIATION:  
SHOWING POSITIONS OF  
MINIMUM CLEARANCE AT  
TOP CROSSARM LEVEL

PLAN ON CROSSARMS  
1:100

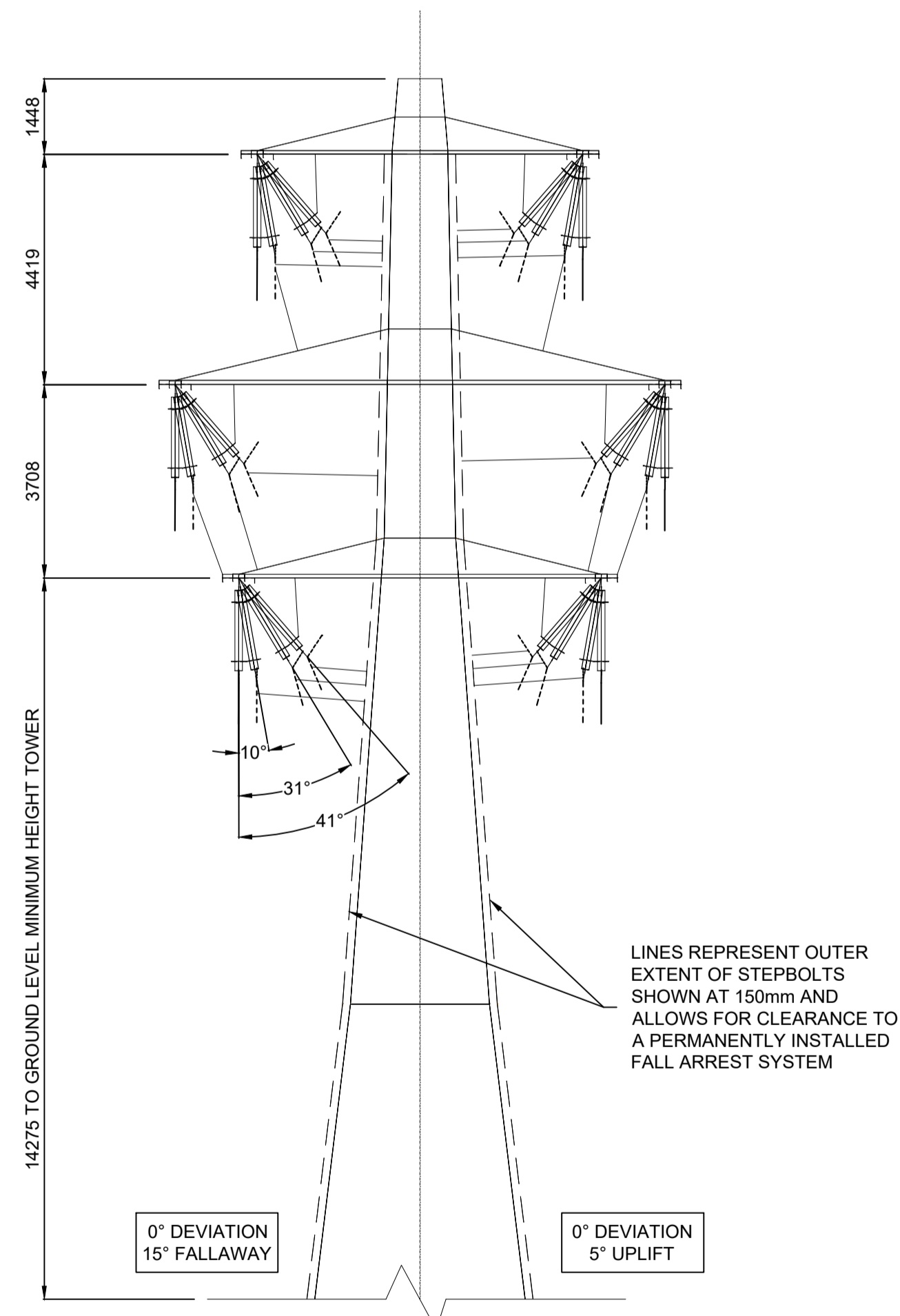

TRANSVERSE ELEVATION  
1:100

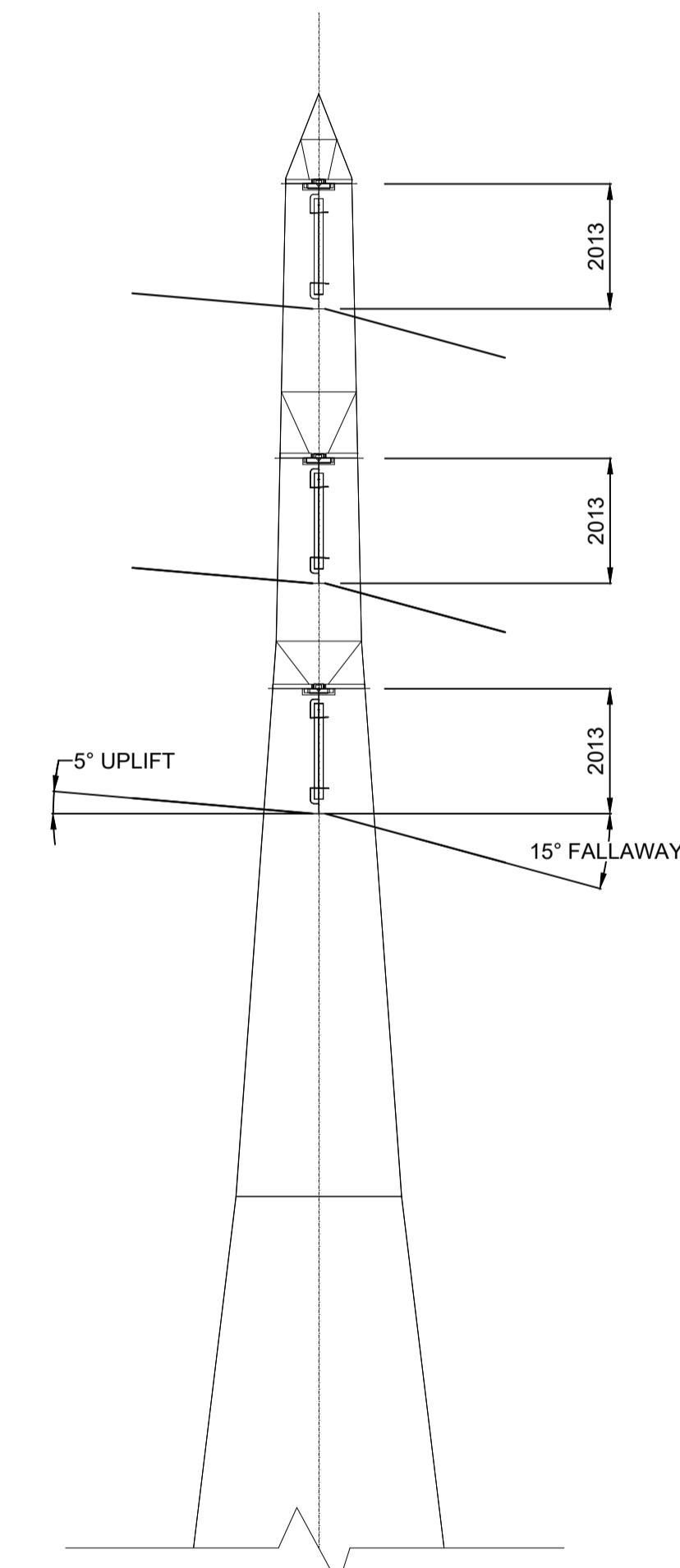

LONGITUDINAL ELEVATION  
1:100

Contains Ordnance Survey data. © Crown copyright and database rights 2022. Ordnance Survey 100030649

P01.1	SO	06/09/2022	DCO APPLICATION	LY	EW	TB
Rev	Status	Rev. Date	Purpose of revision	Drawn	Check'd	Apprv'd

NOTES:

- The proposed design of the structure shown is illustrative only and will be subject to change as part of detailed design development. Any changes will be limited to being within the constraints included in the Development Consent Order (application document reference TR010032/APP/3.1).
- All dimensions are in millimetres unless stated otherwise.
- These are the assumed pylon types for Pylons PAB13R, PAB15R, PAB16R however is subject to change at detailed design.

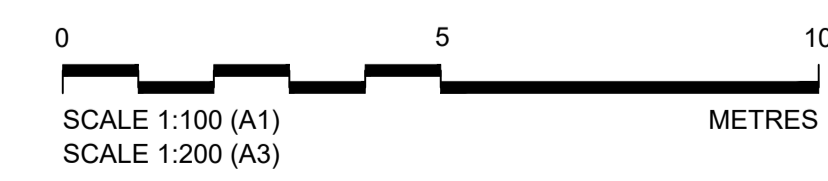

Client

Project

LOWER THAMES CROSSING

Status	Initial Status or WIP	Original Size	A1	Revision	P01.1
Application Document Number	TR010032/APP/2.9	Scale	AS SHOWN		
Drawing title	PYLON GENERAL ARRANGEMENT REGULATION 5(2)(o) AND 6(2) SHEET 5 - L7c D E3				
Drawing Number	HE540039-CJV-BOP-SZA_RX000000_-DR-CH-10811				

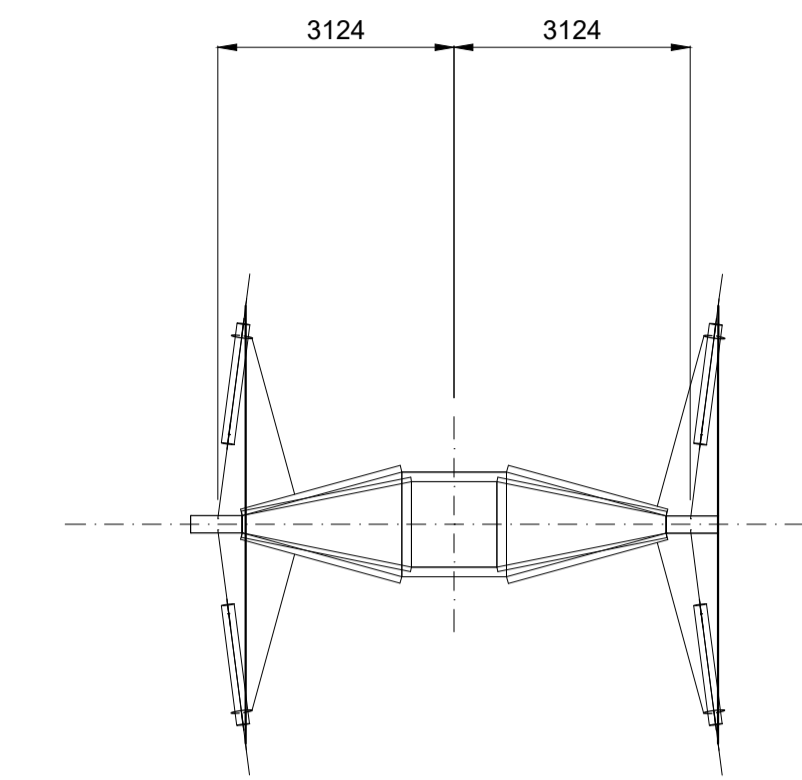
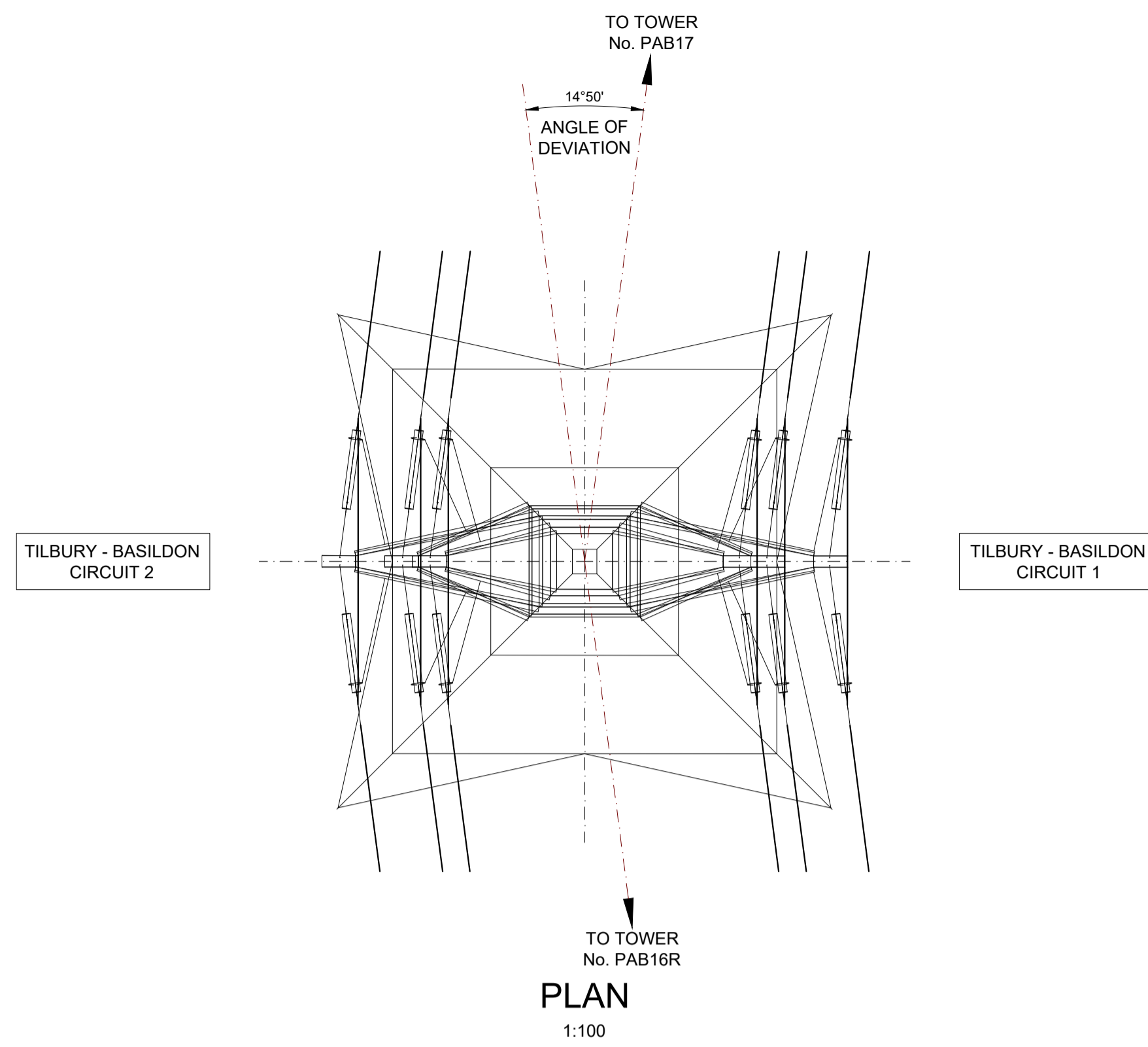

PLAN ON TOP CROSSARMS  
1:100

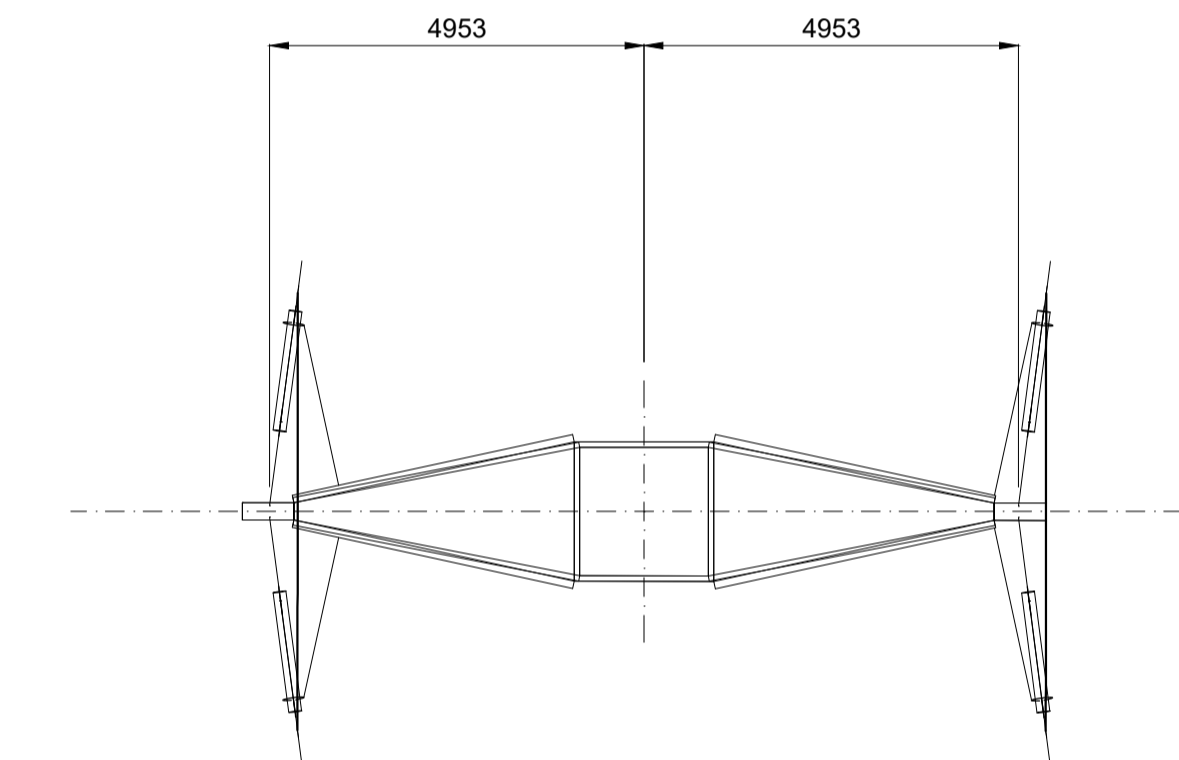

PLAN ON MIDDLE CROSSARMS  
1:100

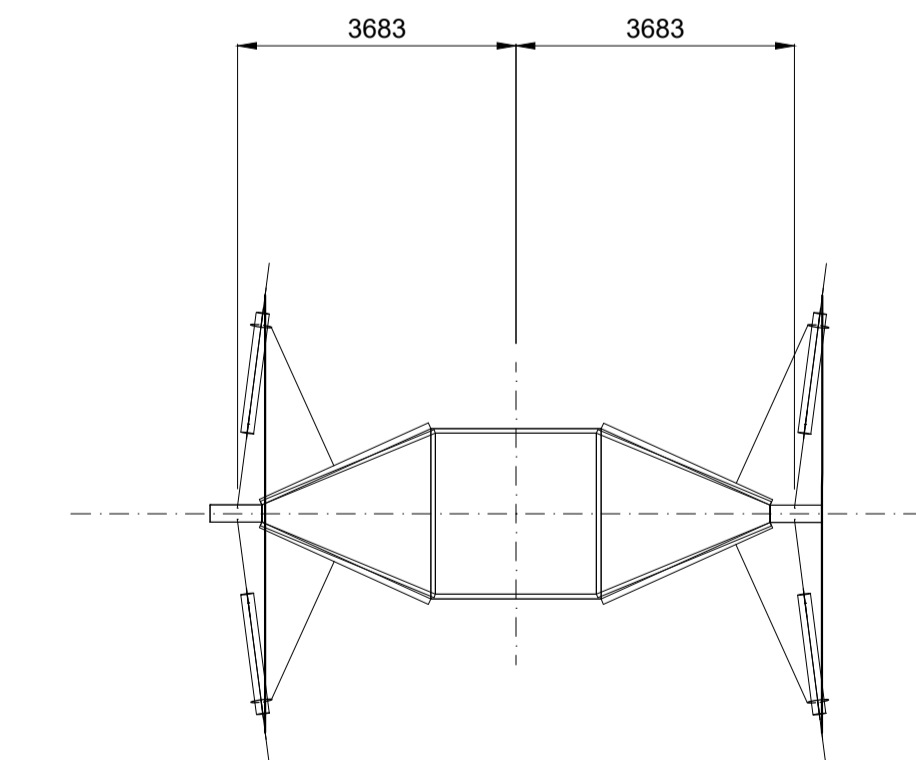

PLAN ON BOTTOM CROSSARMS  
1:100

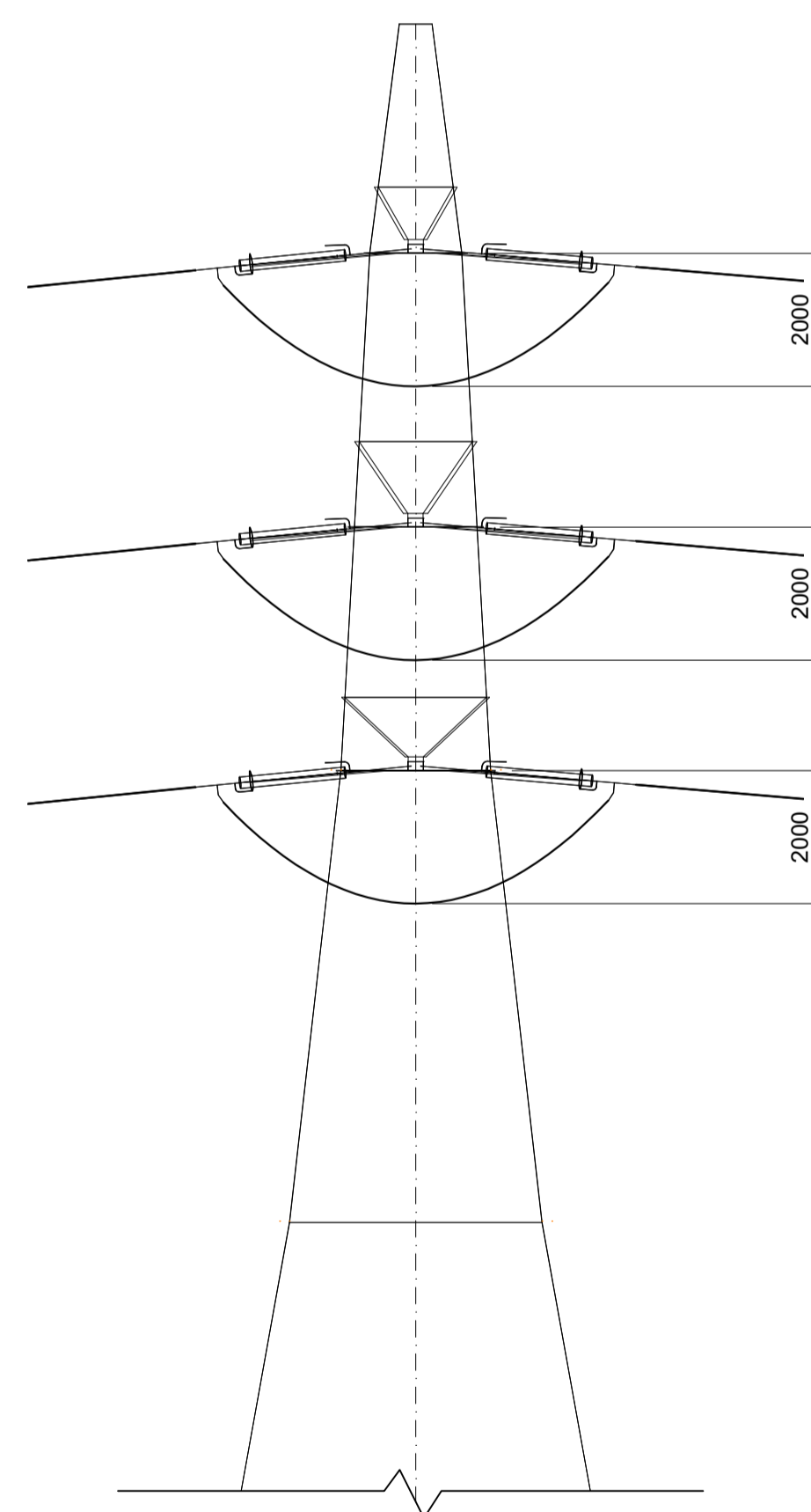

LONGITUDINAL ELEVATION  
SHOWING TILBURY - BASILDON  
CIRCUIT 2 ONLY  
1:100

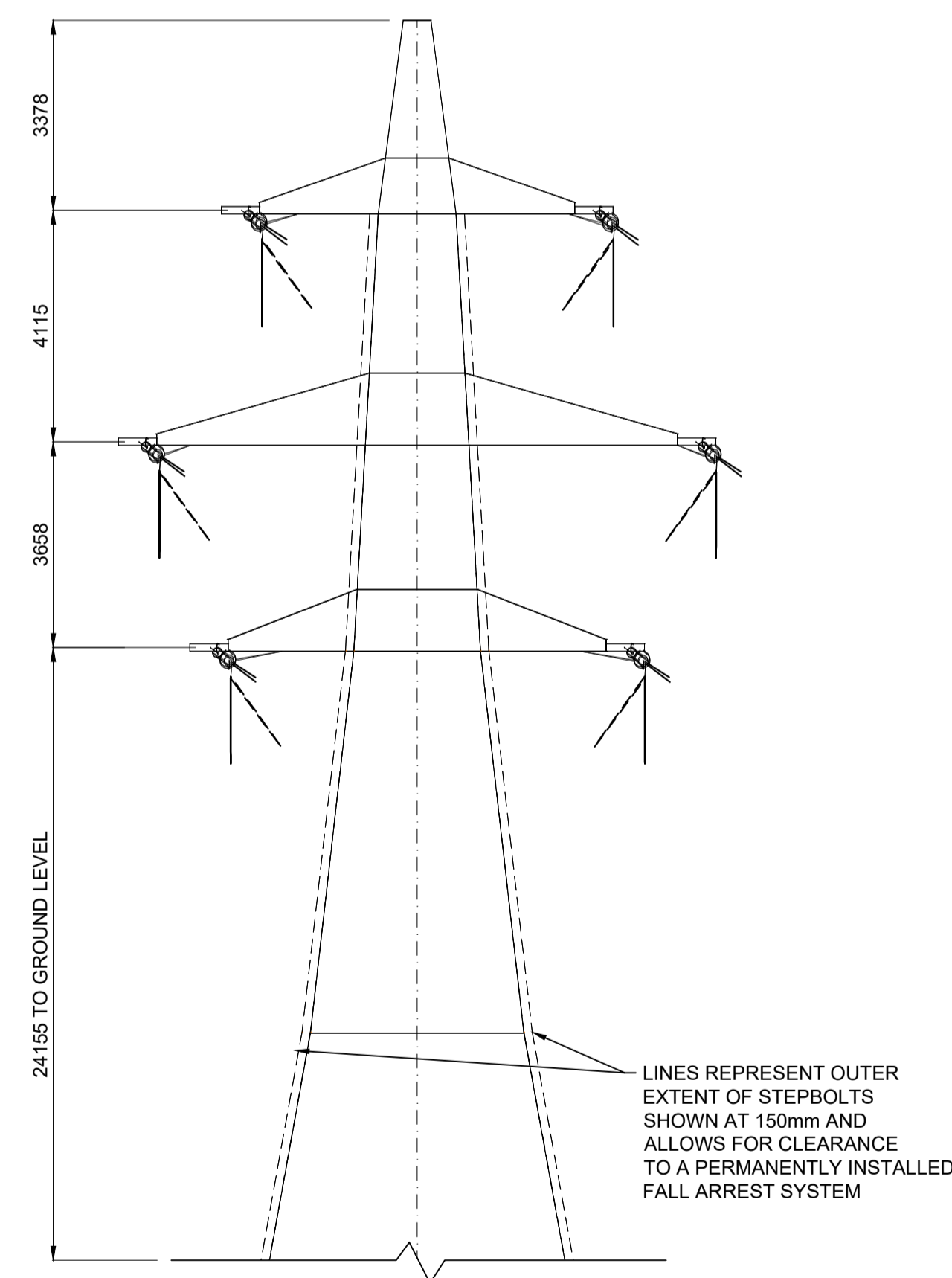

TRANSVERSE ELEVATION  
1:100

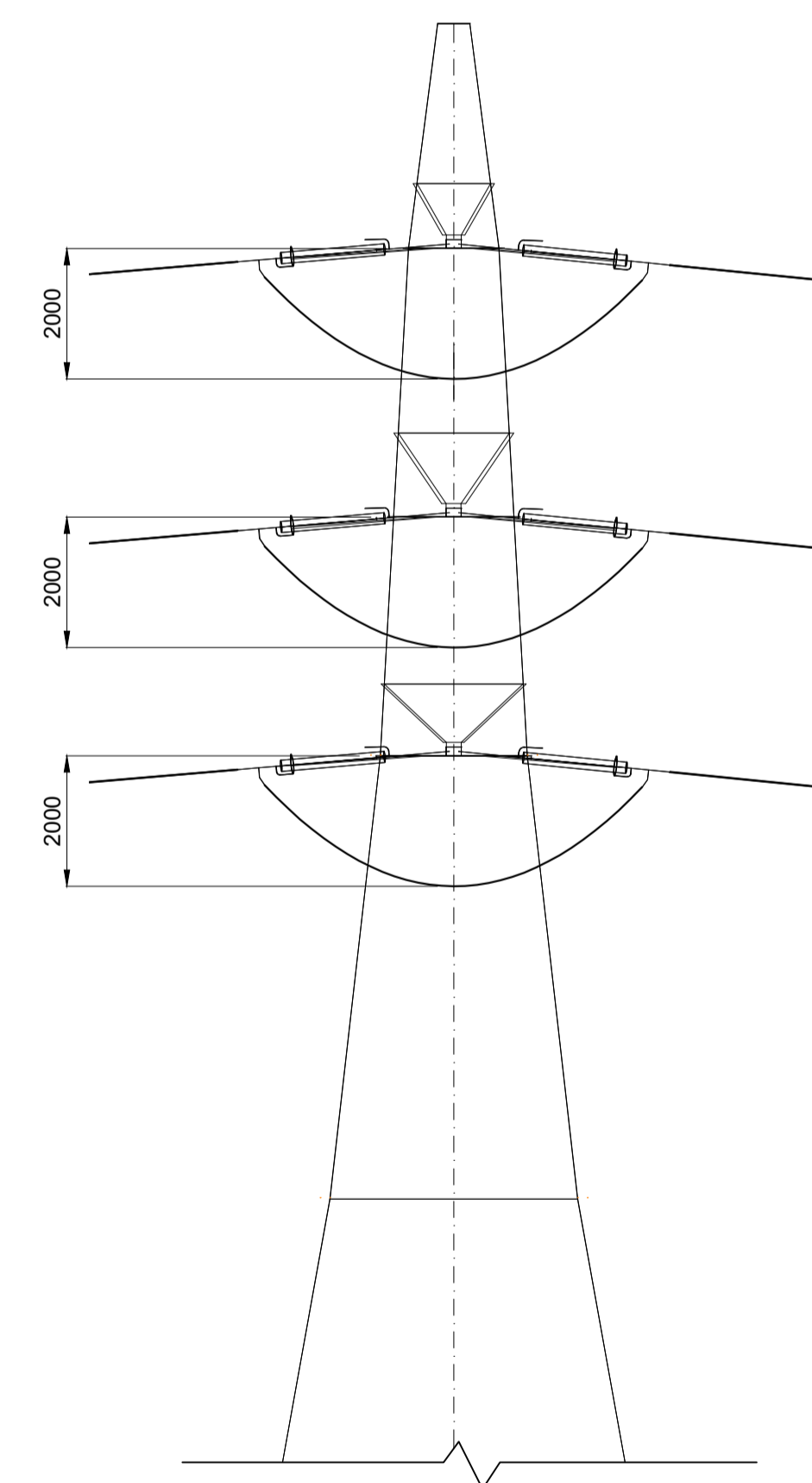

LONGITUDINAL ELEVATION  
SHOWING TILBURY - BASILDON  
CIRCUIT 1 ONLY  
1:100

Contains Ordnance Survey data. © Crown copyright and database rights 2022. Ordnance Survey 100030649

NOTES:

- The proposed design of the structure shown is illustrative only and will be subject to change as part of detailed design development. Any changes will be limited to being within the constraints included in the Development Consent Order (application document reference TR010032/APP/3.1).
- All dimensions are in millimetres unless stated otherwise.
- These are the assumed pylon types for Pylons PAB14R and PAB17R however is subject to change at detailed design.

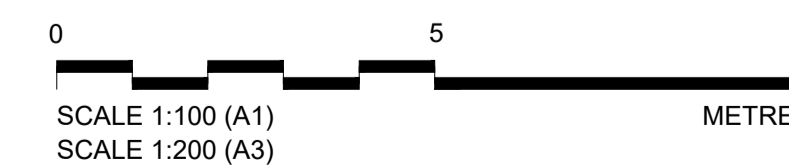

Rev	Status	Rev. Date	Purpose of revision	Drawn	Chk'd	Apprv'd
P01.1	SO	06/09/2022	DCO APPLICATION	LY	EW	TB

Client  
**national highways**

Project  
**LOWER THAMES CROSSING**

Status	Initial Status or WIP	Original Size	Revision
Application Document Number	TR010032/APP/2.9	A1	P01.1
Scale	AS SHOWN		
Drawing title	<b>PYLON GENERAL ARRANGEMENT REGULATION 5(2)(o) AND 6(2) SHEET 6 - L7c D30 E9</b>		
Drawing Number	HE540039-CJV-BOP-SZA_RX000000_-DR-CH-10812		

NOTE:  
CONDUCTOR TYPE FOR ALL SECTIONS FROM PEA07 TO PEA18 IS TO BE CONFIRMED PRIOR TO THE ORDERING OF ANY MATERIALS. ACSR JAGUAR CONDUCTOR OR ASSUMED AT THE DESIGN STAGE BASED ON INFORMATION PROVIDED BY THE UKPN. IF THE CONDUCTOR IS IDENTIFIED TO BE NON-JAGUAR, THE DESIGN OFFICE IS TO BE CONTACTED.

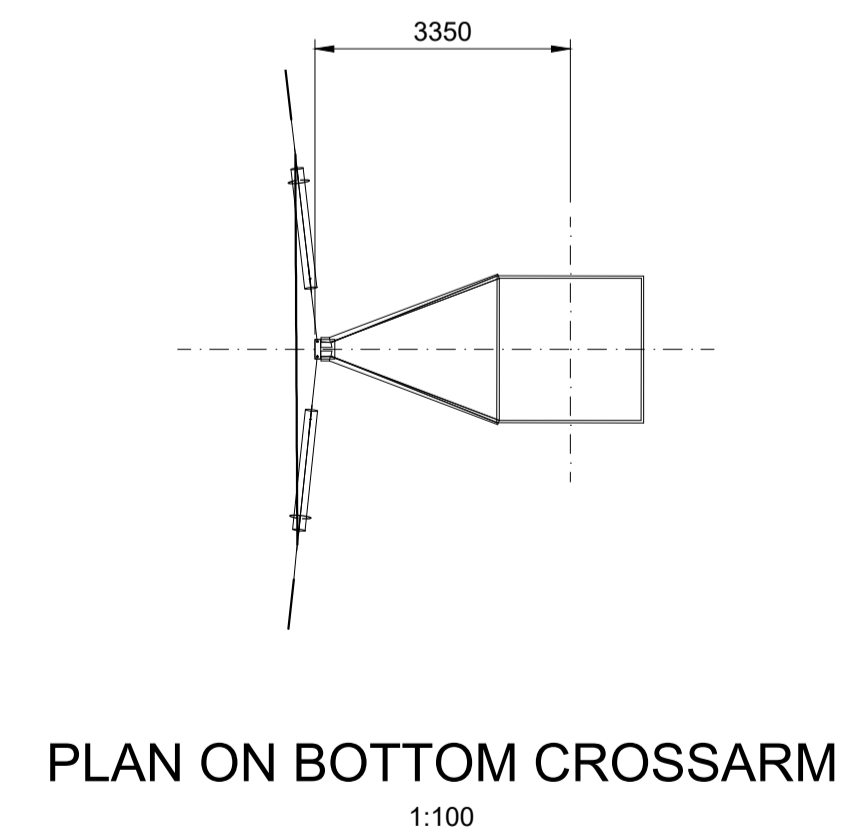
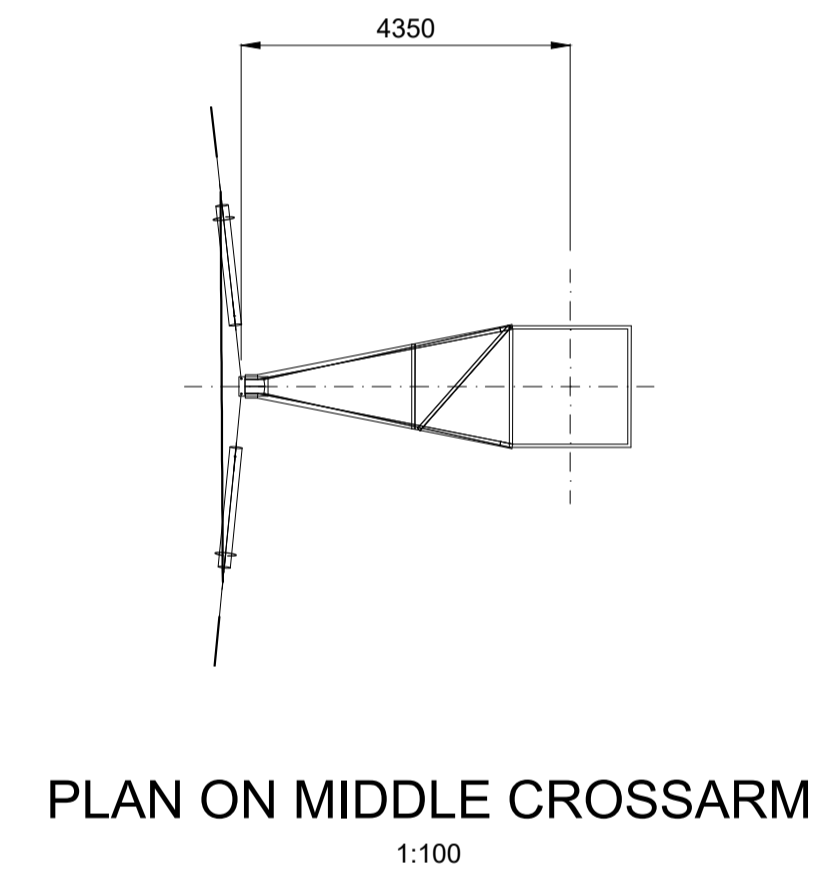
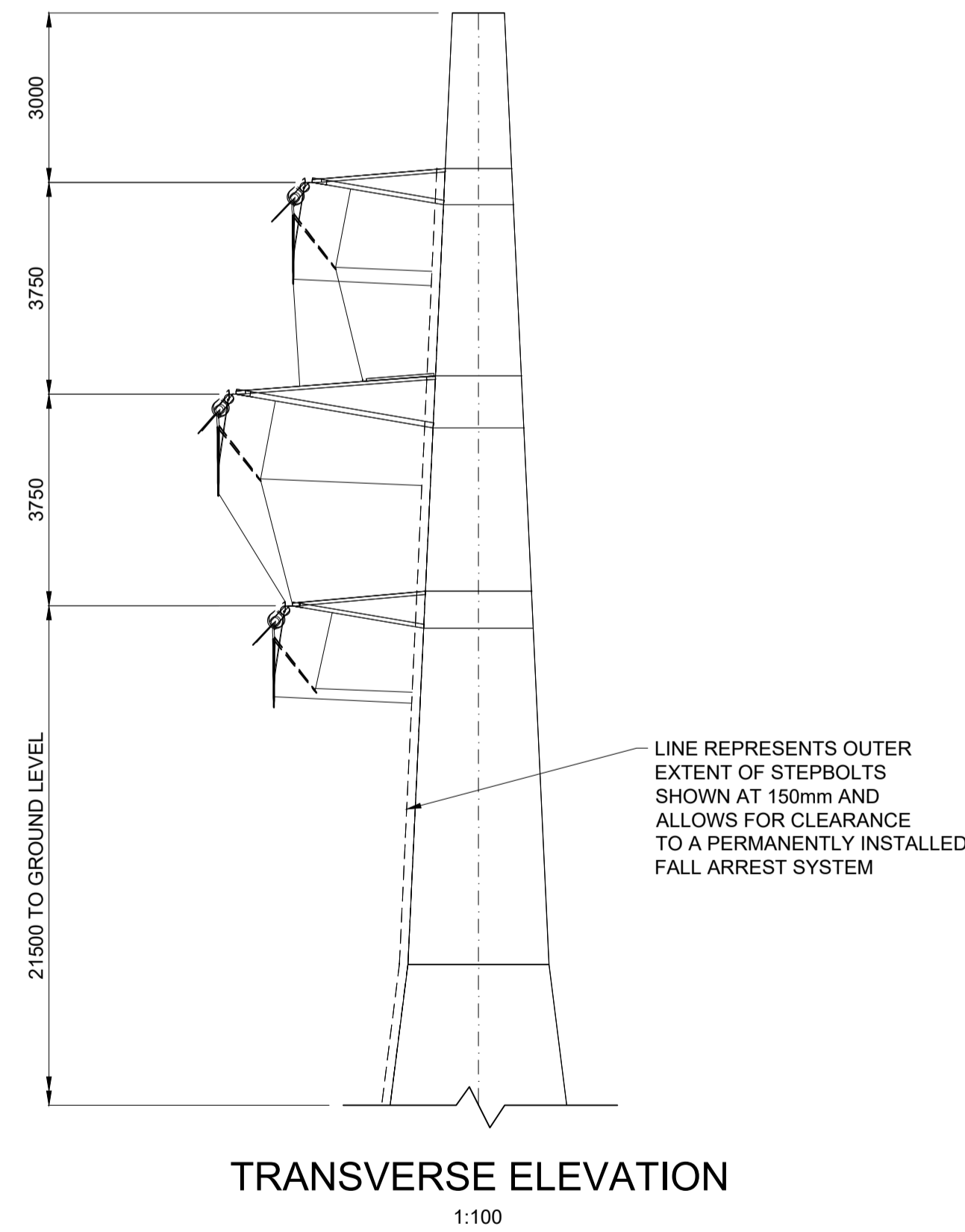
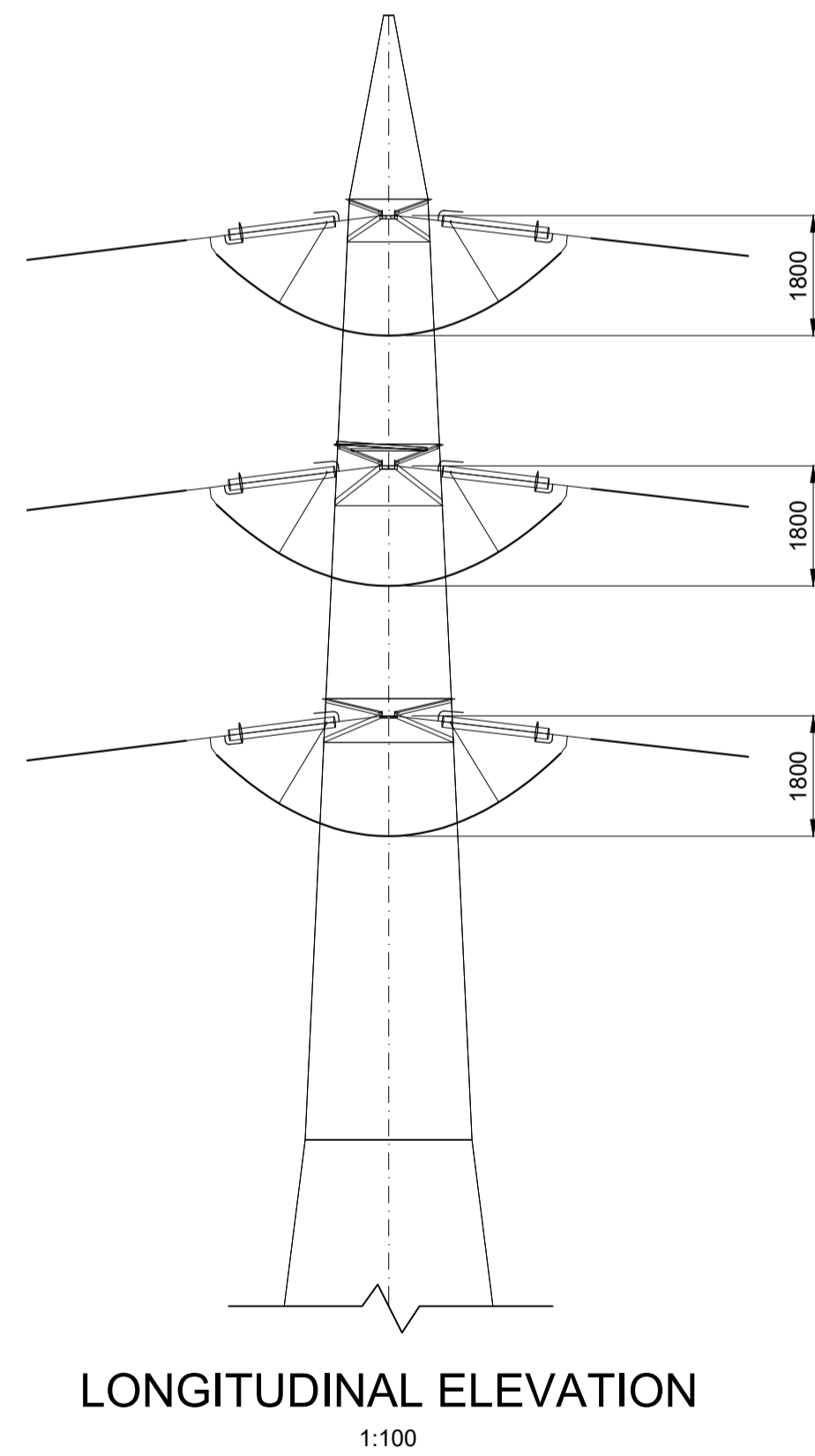
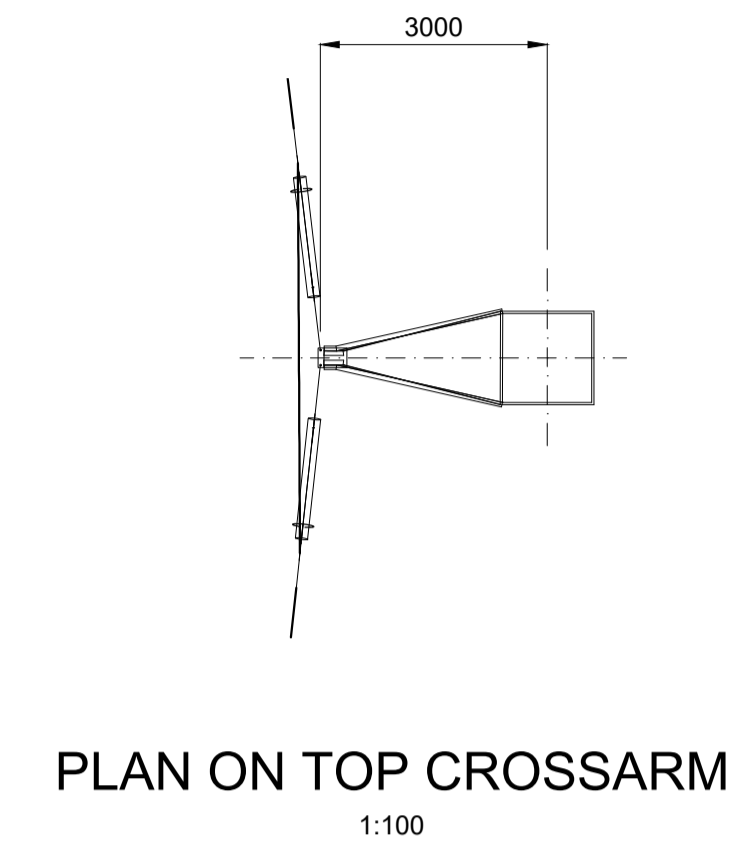
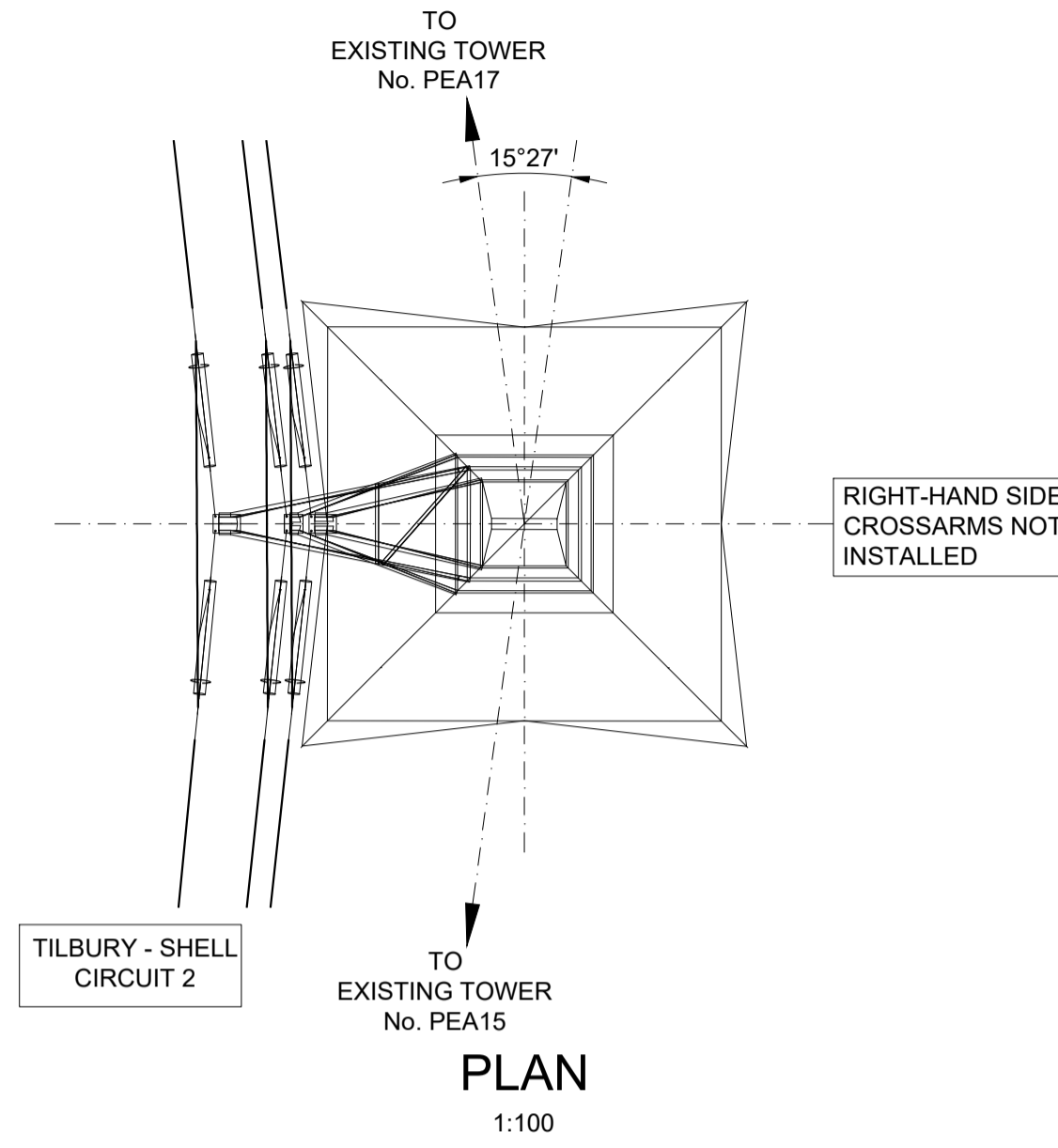

Contains Ordnance Survey data. © Crown copyright and database rights 2022. Ordnance Survey 100030649

NOTES:

1. The proposed design of the structure shown is illustrative only and will be subject to change as part of detailed design development. Any changes will be limited to being within the constraints included in the Development Consent Order (application document reference TR010032/APP/3.1).
2. All dimensions are in millimetres unless stated otherwise.
3. This is the assumed pylon type for Pylon PEA16T however is subject to change at detailed design.

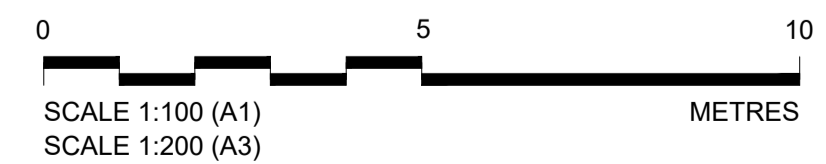

Rev	Status	Rev. Date	Purpose of revision	Drawn	Check'd	Apprv'd
P01.1	SO	06/09/2022	DCO APPLICATION	LY	EW	TB

Client  
**national highways**  
Project  
**LOWER THAMES CROSSING**

Status	Initial Status or WIP	Original Size	A1	Revision	P01.1
Application Document Number	TR010032/APP/2.9	Scale	AS SHOWN		
Drawing title	<b>PYLON GENERAL ARRANGEMENT REGULATION 5(2)(o) AND 6(2) SHEET 7 - L7c DT E9</b>				
Drawing Number	HE540039-CJV-BOP-SZA_RX000000_-DR-CH-10813				

If you need help accessing this or any other National Highways information, please call **0300 123 5000** and we will help you.

© Crown copyright 2022.

You may re-use this information (not including logos) free of charge in any format or medium, under the terms of the Open Government Licence. To view this licence:

visit [www.nationalarchives.gov.uk/doc/open-government-licence/](http://www.nationalarchives.gov.uk/doc/open-government-licence/)

write to the **Information Policy Team, The National Archives, Kew, London TW9 4DU**, or email [psi@nationalarchives.gsi.gov.uk](mailto:psi@nationalarchives.gsi.gov.uk).

Mapping (where present): © Crown copyright and database rights 2022 OS 100030649. You are permitted to use this data solely to enable you to respond to, or interact with, the organisation that provided you with the data. You are not permitted to copy, sub-licence, distribute or sell any of this data to third parties in any form.

If you have any enquiries about this publication email [info@nationalhighways.co.uk](mailto:info@nationalhighways.co.uk) or call **0300 123 5000\***.

\*Calls to 03 numbers cost no more than a national rate call to an 01 or 02 number and must count towards any inclusive minutes in the same way as 01 and 02 calls.

These rules apply to calls from any type of line including mobile, BT, other fixed line or payphone. Calls may be recorded or monitored.

Printed on paper from well-managed forests and other controlled sources when issued directly by National Highways.

Registered office Bridge House, 1 Walnut Tree Close, Guildford GU1 4LZ

National Highways Company Limited registered in England and Wales number 09346363